



**ULTRACARE**

*At the Cutting Edge of Industry*

**K23/K25**

**THROUGH FEED FOUR  
SIDE PLANING  
MACHINE**

INSTRUCTION MANUAL No.2034/2

## MANUFACTURERS E.C. DECLARATION OF CONFORMITY

The following machine has undergone "Conformity Assessment" and has undergone Self Assessment in accordance with:-

Schedule IV of the Supply of Machinery (Safety) Regulations 1992  
and Amendment No. 2063

### COMPANY

Wadkin Ultracare Limited  
Franks Road  
Hilltop Industrial Park  
Bardon  
Leicestershire  
LE67 1TT

### RESPONSIBLE PERSON

Mr J P Smith (Director)

### MACHINE DESCRIPTION

TYPE Four Sided Planer

MODEL K23/K25

### DIRECTIVES COMPLIED WITH

Supply of Machinery (Safety) Regulations 1992  
Amendment No. 2063 1994  
Draft Proposal CEN/TC 142  
ISO 9001 Part 1

SIGNED ON BEHALF OF WADKIN  
ULTRACARE LTD.



.....

# CONTENTS

## EXTENT OF MANUAL

Section		Page
<b>1</b>	<b>HEALTH AND SAFETY</b>	<b>1-1</b>
1.1	Health and Safety	1-1
1.1.1	Factories Act	1-1
1.1.2	Health and Safety at Work Act	1-2
1.1.3	Electricity Regulations	1-2
1.1.4	Provisions and use of Work Equipment Regulations	1-2
1.1.5	Woodworking Machines Regulations	1-2
1.1.6	Other Documents for Reference	1-2
1.2	Supply of Machinery (Safety) Regulations 1992	1-3
1.3	Specific Information	1-3
1.3.1	Noise	1-3
1.3.2	Dust	1-4
1.3.3	Warning	1-5
<b>2</b>	<b>MACHINE SPECIFICATION</b>	<b>2-1</b>
<b>3</b>	<b>INSTALLATION</b>	<b>3-1</b>
3.1	Receipt of the Machine	3-1
3.2	Preparation for Installation	3-1
3.3	Lifting the Machine	3-1
3.4	Locating the Machine	3-2
3.5	Connecting the Services	3-2
3.5.1	Electrical Supply	3-2
3.5.2	Pneumatic Air Supply	3-3
3.5.3	Dust Extraction	3-3
<b>4</b>	<b>MACHINE USAGE AND CONTROLS</b>	<b>4-1</b>
4-1	Safe Practices	4-1
4.1.1	Pre-operation Checks	4-1
4.1.2	Checks During Operation	4-1
4.1.3	Safety Devices	4-2
4.2	Machine Controls	4-3
4.2.1	Machine Control Panel	4-3
4.2.2	Machine Front Face	4-5

<b>5</b>	<b>SETTING-UP THE MACHINE</b>	<b>5-1</b>
5.1	General	5-1
5.1.1	Preparation	5-1
<b>Section</b>		<b>Page</b>
5.1.2	Remove/Refit Cutter Block in Spindle	5-2
5.2	Setting First Bottom Head	5-3
5.3	Setting Fence Side Head	5-5
5.4	Setting Near Side Head	5-7
5.5	Setting First Top Head	5-10
5.6	First Top Head Pad Pressure and Chipbreaker	5-12
5.7	Setting Second Top Head, Pad Pressure and Chipbreaker	5-14
5.8	Setting Second Bottom Head	5-15
5.9	Setting the Feed Rolls	5-17
5.10	Infeed Table and Fence Adjustment	5-21
<b>6</b>	<b>OPERATION</b>	<b>6-1</b>
6.1	General	6-1
6.1.1	Pre-operation Checks	6-1
6.1.2	Setting Controls and Adjustments	6-1
<b>7</b>	<b>MAINTENANCE</b>	<b>7-1</b>
7.1	General	7-1
7.2	Scheduled Maintenance	7-1
7.2.1	Daily	7-1
7.2.2	Monthly	7-2
7.2.3	Three-Monthly	7-2
7.3	Unscheduled Maintenance	7-3
7.3.1	Removal of K23/K25 Horizontal Spindles (Horizontal Heads)	7-4
7.3.2	Removal of K23/K25 First Bottom Head Spindle	7-5
7.3.3	Removal of K23/K25 Vertical Spindles (Vertical Heads)	7-6
7.3.4	Replacing K23/K25 Top and Bottom Drive Belts	7-7
7.3.5	Replacing K23/K25 Fence and Near Side Head Drive Belts	7-8
7.4	Fault Finding	7-9
7.4.1	General	7-9
7.4.2	Workpiece Faults	7-9
7.4.3	Machine Faults	7-10
7.5	Lubrication Chart	7-12
7.5.1	Lubricants Specified	7-12

7.5.2	Approved Lubricants	7-12
7.6	Tool and Toolholder Care	7-13
<b>8</b>	<b>ADDITIONAL EQUIPMENT</b>	<b>8-1</b>
8.1	General	8-1
8.2	Meterage Counter	8-1
8.3	Short Infeed Table	8-3
8.4	Splitting Bedplate	8-6
8.5	99 Position Programmable Memory	8-8
<b>9</b>	<b>CIRCUIT DIAGRAMS</b>	<b>9-1</b>
9.1	Pneumatics Diagram	9-1
9.2	Electrics Diagram	
	<b>GLOSSARY</b>	

www.wadkin.com  
info@wadkin.com

## EXTENT OF MANUAL

---

This Operator Manual is intended to provide users with all relevant information concerning the operation and scheduled maintenance of a Through Feed Moulding Machine, Model K23/K25.

The document is produced in seven sections.

Section One gives advice general safety aspects of the machine usage including references to the various current statutory and safety regulations in force, advice on record keeping of machine operation and maintenance, and also instructions on recommended procedures when accepting and receiving the machine from the manufacturer.

Sections Two to Seven provide the information necessary to install, operate and maintain the machine including procedures for fault finding.

At the end of the manual is a Glossary of terms used throughout the body of the manual.

The policy of the Company is one of continuous development, and the company reserves the right to alter specification without prior notice.

No part of this publication shall be produced in any way without the express permission of the Company.

# 1 HEALTH AND SAFETY

---

This Section covers all aspects of safe operation and safe use of woodworking machinery. It refers to various statutory Health and Safety regulations, and also includes information and advice derived from many years' experience in the building, operation and maintenance of woodworking machinery.

**It is of the utmost importance that the user or employer reads this Section of the document and understands clearly all of the stated requirements concerning safe operation of the equipment.**

## 1.1 Health and Safety

There are a number of statutory regulations which apply to the safe operation of woodworking machinery in the UK. These regulations are listed below, and the user is advised to refer to the relevant parts of these regulations and ensure that the requirements are complied with.

Where the machinery is used outside the UK, then the regulations of that country will apply, and should be complied with.

*Note:*

*The list below relates to the most recent published editions of the regulations including all amendments and supplements.*

Factories Act.

Health and Safety at Work Act.

Electricity Regulations.

Provision and use of Work Equipment Regulations.

Woodworking Machines Regulations.

### 1.1.1 Factories Act

This Act requires that rotating machinery shall be of good mechanical construction and that it shall be **properly maintained and serviced by competent and experienced persons.**

### 1.1.2 Health and Safety at Work Act

This Act imposes obligations to apply similar standards to those of the Factories Act as a minimum requirement, **especially where a machine is installed in a place of work where no suitable legislation applies.**

### 1.1.3 Electricity Regulations

These regulations place general requirements on the installation and maintenance of electrical equipment. Users should be aware of the requirements concerning the availability of lighting and free working space for maintenance personnel, and the importance of personnel being fully competent and trained when working on electrical equipment.

### 1.1.4 Provision and Use of Work Equipment Regulations

Compliance with these regulations is necessary for equipment to be considered to be conforming with the EC declaration of conformity. The regulations also place obligations on the user (see Section 1.2).

### 1.1.5 Woodworking Machines Regulations

These regulations place absolute legal requirements on employers and users to ensure **that all fitted guards and safety devices are always used, securely fitted, correctly adjusted and properly maintained.**

The regulations also require that **maintenance be undertaken only by suitably qualified and competent personnel, and that all power supplies are isolated from the machine before any maintenance is undertaken.**

It is also required that **operators (users) receive suitable training and instruction into the possible dangers arising from machine usage and that local working practices are followed.**

### 1.1.6 Other Documents for Reference

Other documents which refer to woodworking machinery operation and maintenance in the UK include:

Noise at Work Regulations.

Control of Substances Hazardous to Health Regulations.

Code of Practice BS5304 - Safeguard of Machinery.

Code of Practice BS6854 - Safeguard of Woodworking Machines.

Health and Safety Executive note IND(G) 1(L).



## 1.2 Supply of Machinery (Safety) Regulations 1992

A machine manufactured in accordance with the Essential Health and Safety Requirements of the Supply of Machinery (Safety) Regulations 1992, complies with the EC conformity requirements and can thus have the CE mark appended (Harmonised Standard PR EN 12750: 1997).

These regulations also impose legal requirements on both the employer and the user of the machine with regard to proper usage, user working conditions, risks of injury and many more. These requirements are wide ranging, and in some cases specific to only certain types of machine or process. Some of the more general requirements which apply to woodworking machinery are briefly detailed below.

- 1 An employer shall ensure that the equipment is constructed/adapted as to be suitable for the purpose that it is used.
- 2 In selecting the equipment, the employer shall have due regard to the working conditions and the risks to health and safety of persons which exist in the premises in which the equipment is to be used.
- 3 The employer shall ensure that the equipment is used for the operations for which, and under the conditions for which it is suitable.

Other requirements include provision of suitable training of users, provision of suitable documentation (information and instructions), and declarations of any specific risks.

### 1.3 Specific Information

Section 4 of this manual - Machine Usage and Controls identifies and details general safe working practices and specific local practices which should be adopted when using the machine.

Particular attention should be drawn to the process of dividing the workpiece ie by saw units or multi-profiling units. Under such operation a Catching Finger Device (sometimes known as an Anti Kickback unit), **MUST BE FITTED** to prevent ejection of divided parts and splinters of the workpiece.

In addition to this information two hazards, specific to woodworking machinery should be considered in more detail.

#### 1.3.1 Noise

Noise levels can vary widely depending upon the machine and the conditions of use.

The Noise at Work Regulations place legal duties on employers to prevent damage to hearing. Noise levels of up to 140dB are considered.

**Employers** are required to take reasonably practicable measures to reduce noise levels where a person is expected to be exposed to continuous noise in excess of 90dB over a working day. Additionally suitable ear protection must be made available.

Machines producing 'unhealthy noise levels' must be marked with a warning of the need to wear ear protection.

Additionally, it may be necessary to identify particular areas of the workplace 'ear protection zones'.

NOISE EMISSION CHART		
MODEL:- PLANER TYPE :- K23/K25. 50HZ 415V		
DECLARED NOISE EMISSION VALUES in accordance with ISO4871		
	Idling	Operating
Declared A-weighted sound power level (LWAD) in dB re lpw	90.98	101.81
Declared A-weighted sound pressure level (LpAd) in dB re 20uPa	75.20	86.04
Environmental correction factor (K)	= 3	
Values determined according to specific test code ISO7960		

The figures quoted are emission levels and are not necessarily safe working levels. Whilst there is a correlation between the emission and exposure levels, this cannot be used reliably to determine whether or not further precautions are required. Factors that influence the actual level of exposure of the workforce include the characteristics of the work room, the other sources of noise etc. i.e. the number of machines and other adjacent processes. Also the permissible exposure level can vary from country to country. This information, however, will enable the user of the machine to make a better evaluation of the hazard and risk.

### 1.3.2 Dust

Wood dust can be harmful to health through inhalation and also skin contact.

The Control of Substances Hazardous to Health Regulations place legal requirements on **employers** to prevent exposure of the user to substances hazardous to health or, where prevention is not practicable, to adequately control the exposure. Adequate control should be achieved by measures other than provision of personal protective equipment.

The Regulations require that airborne dust levels should not exceed 5mg/m<sup>3</sup>.

### 1.3.3 WARNINGS

#### Notice to operators

Read and follow the guide lines given in Safeguarding Machines and Safety Notes which are repeated on the front of the machine.

#### Before Operating the Machine

Ensure that all guards and fences are securely fitted and correctly adjusted. Guards and other safety devices are NOT to be removed while the machine is in operation. They are there for YOUR SAFETY.

Ensure cutters/blades are the correct type and rotate in correct direction of cut, are sharp and securely fastened.

Cutter equipment is suitable for machine spindle speed.

Remove or fasten loose clothing; confine long hair and remove jewellery, etc.

Ensure sufficient working space is provided and that lighting is adequate.

Switch on all dust extraction equipment, ensure it is working correctly.

#### During machining

Wear suitable protective equipment, e.g. goggles, ear defenders, dust mask.

Stop the machine before making adjustments or cleaning woodchips from the work area.

Keep the floor area around the machine clean and free from wood refuse.

Do not allow the floor to become slippery with oil or grease.

Report any machine malfunction or operator hazard to a person in authority immediately. Do not attempt to repair the machine unless qualified to do so.

Ensure all power sources are isolated before commencing any maintenance work.

Comply with the Woodworking Machines regulations. Failure to do so could result in legal proceedings.

## 2 MACHINE SPECIFICATION

---

### Machine Details

<b>Model</b>	K23/ (K25)
<b>Weight</b>	3900kg
<b>Dimensions</b>	Refer to machine Foundation Plan
<b>Services</b>	Refer to the machine Specification Plate located on the machine frame

### Capacities and Adjustments

<b>Maximum timber size admitted</b>	240mm x 140mm (260 x 140)
<b>Maximum finished work size</b>	230mm x 120mm
<b>Feed speeds</b>	0-22m/min
<b>Compressed Air Requirement</b>	0.25m <sup>3</sup> /min @ 5bar
<b>Dust Extraction</b>	Refer to machine Foundation Plan

### Maximum cutting circles.

<b>First bottom head</b>	125mm
<b>Fence side head</b>	200mm
<b>Near side head</b>	200mm
<b>First top head</b>	210mm
<b>Second top head</b>	210mm
<b>Second bottom head</b>	200mm

### Minimum cutting circles

<b>First bottom head</b>	125mm
<b>Other heads</b>	120mm

### Note

This unit will operate between 41 & 104 Deg. F (5 to 40 Deg. C); upto 3300ft (1000m); 20% to 95% RH (non condensing); and transportation and storage conditions of -13 to 131 Deg. F (-25 to 55 Deg. C).

## 3 INSTALLATION

### 3.1 Receipt of the Machine

Before accepting the machine at its destination check the packages/items against the bill of lading. Confirm that all listed fittings/accessories have been received and carry out a visual inspection of the packages/items for obvious signs of damage.

Report any omissions or damage; note these for any future reference.

### 3.2 Preparation for Installation

Ensure that all the necessary external services are available ie electricity, compressed air, etc., as identified in Section 2 Machine Specification.

Check also that adequate space is available on the installation site for lifting and manoeuvring access.

Check that suitable and approved lifting equipment is available and is of adequate capacity:

Refer to the Foundation Plan for details of the floor area required and for any special foundations necessary

Ensure that the final location of the machine has been levelled.

### 3.3 Lifting the Machine

Verify the lifting equipment used is capable of lifting the weight of the machine as a minimum

The machine should lift straight if the chain nearest the infeed end (to the right of the machine when viewed from the front) is slightly shorter. The angle between the chains must not exceed 90°.

Remove the shackles before opening the hood.

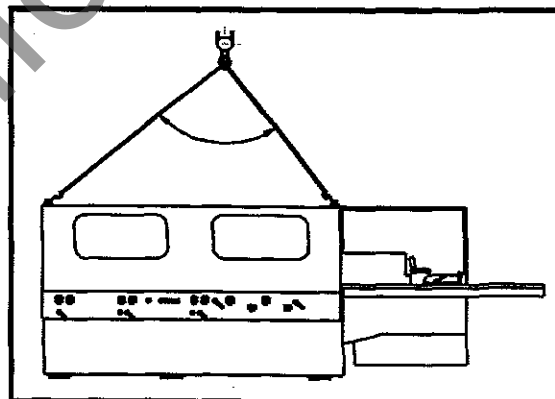

### 3.4 Locating the Machine

Locate lifting slings into the two 'D' lifting points on the machine and secure.

Position a steel levelling plate at each machine jacking screw point (refer to the machine Foundation Plan).

Lift and position the machine on the prepared location.

Level the machine (as detailed below) using an engineer's level by adjusting the jacking screws located at each machine foot position.

#### **Levelling longitudinally**

With the engineer's level lengthways on the table of the machine, adjust the machine longitudinally by adjusting the jacking screws. Check level at approximately every 300mm along the machine length. Deviation should not exceed 0.1mm/m.

#### **Levelling transversely**

Position the engineer's level across the table (at right angle to the fence), and adjust the machine transversely by adjusting the jacking screws. Repeat this action at points similar to the longitudinal checks. Deviation should not exceed 0.1mm/m.

#### **WARNING:**

The machine must be firmly bolted down before connecting any services.

### 3.5 Connecting the Services

#### 3.5.1 Electrical Supply

The customer is responsible for an electrical supply suitable to meet the power requirements of the machine. These requirements are shown on the machine Specification Plate on the machine frame, and are also shown on the electrical schematic/connection diagram accompanying the machine.

Electrical connections should be made to the isolating switch on the electrical control cubicle.

#### **WARNING:**

Connection of the supply must be made by a competent and experienced electrician.

**US & Canada - All supply wiring and conduit sizes must be sized in accordance with the NEC (National Electric Code – NFPA 70) and applicable state, county or jurisdictional codes, or CEC (Canadian Electric Code)**

The connection procedure should include, but not be limited to:

Confirm that the supply is of the correct voltage, phase and frequency to that identified on the machine Specification Plate.

Check that the incoming fuse ratings can accommodate the full load current shown on the machine Specification Plate.

Connect the incoming supply to the relevant terminals on the electrical control cubicle (L1, L2 and L3).

Make a good earth connection to the machine.

**WARNING:**

**Before continuing further, refer to Section 4 for advice on safe operation of the machine. Also, ensure that when undertaking any of the following operations all relevant safety requirements and procedures detailed in Section 1 are complied with.**

Close the isolator on the electrical control cubicle, and run each spindle in turn to ensure that direction of rotation is correct:

Bottom heads - clockwise when viewed from front.

Top heads - counterclockwise when viewed from front.

Fence side head - counterclockwise when viewed from above.

Near side head - clockwise when viewed from above.

*Note:*

*Incorrect rotation of the spindles can be corrected by reversing any two of the incoming supply connections to the terminals of the electrical control cubicle.*

**WARNING:**

**Phase changes must be made by a competent and experienced electrician.**

### 3.5.2 Compressed Air Supply

The customer is responsible for a compressed air supply suitable to meet the requirements of the machine as shown on the machine Foundation Plan (0.25m<sup>3</sup>/min).

The air supply connection in the machine base is ¼BSP female.

Check the condition of the air connectors, confirm their cleanliness, and make the air connection.

### 3.5.3 Dust Extraction

The customer is responsible for the supply and fitting of suitable dust extraction equipment.

The number and length of the flexible connections from the exhaust hood to the machine should be as shown on the machine Foundation Plan.

See the machine Foundation Plan for:

Airflow requirements in m<sup>3</sup>/hour.

Cross-sectional dimensions of machine extraction connections.

Duct air velocities in m/second.

Average pressure drop at machine extraction connections are shown below.

Duct Diameter (mm)	Required Air Volume (m <sup>3</sup> /hour at 30m/sec)	Pressure Drop (Pa)
120	1222	1000
150	1909	850



## 4 MACHINE USAGE AND CONTROLS

---

*Note:*

*Refer also to Section 1 for information on general statutory requirements when operating woodworking machinery.*

### 4.1 Safe Practices

Safe and proper working practices must be followed when setting-up and operating the machine. Adequate advice and information are readily available in the form of local working practices, notices, warnings and the information contained in this manual.

**IT IS THE OPERATOR'S RESPONSIBILITY TO USE THE MACHINE FOLLOWING THE PROCEDURES LAID DOWN AND ONLY FOR THE PURPOSES FOR WHICH THE MACHINE WAS DESIGNED.**

#### 4.1.1 Pre-operation Checks

All guards and fences are fitted securely and properly adjusted to suit their purpose.

Cutter blocks are securely fitted and that spindle direction of rotation is correct.

Dust extraction equipment is working correctly.

Machine controls are functioning correctly (see Section 4.2).

Adequate working space is provided and lighting is available.

#### 4.1.2 Checks During Operation

Proper protective equipment is available and employed (goggles, ear defenders, face mask, etc).

Area around the machine is kept clean and free of wood refuse.

Any machine malfunction is recorded and reported to person in authority.

Machine is made stationary and electrically isolated before any cleaning of work area or ANY adjustments are made to the machine or ancillary equipment.

#### 4.1.3 Safety Devices

In order to avoid injury or accidental damage to personnel or equipment, a number of interlocking features have been incorporated into the machine operation. These are:

- 1 Infeed trip device trips the operation of the machine feed. The spindles continue to run. This trip level is set through the height of the beam setting.

Before attempting to clear and restart the machine, isolate it from the electrical supply. The feed must be restarted at the control panel after removal of the cause of the trip.

- 2 If the enclosure door is opened during normal operation all spindles and feed rolls stop.
- 3 With the enclosure open, the machine may be used for setting-up and test purposes only.
- 4 The machine feed does not operate unless the spindles are running and locked, and the enclosure is closed.
- 5 Brakes are fitted to all spindles.

www.wadkin.com  
info@wadkin.com

## 4.2 Machine Controls

Controls are fitted in two positions on the machine - the machine control panel at the infeed end of the machine, and the group of controls on the machine front face (below the top heads).

Before using the machine, operators should familiarise themselves with the machine control panel and other controls.

### 4.2.1 Machine Control Panel

The machine control panel is mounted at the infeed end of the machine and consists of a number of buttons, switches and indicators (see Figure 4.2.1).

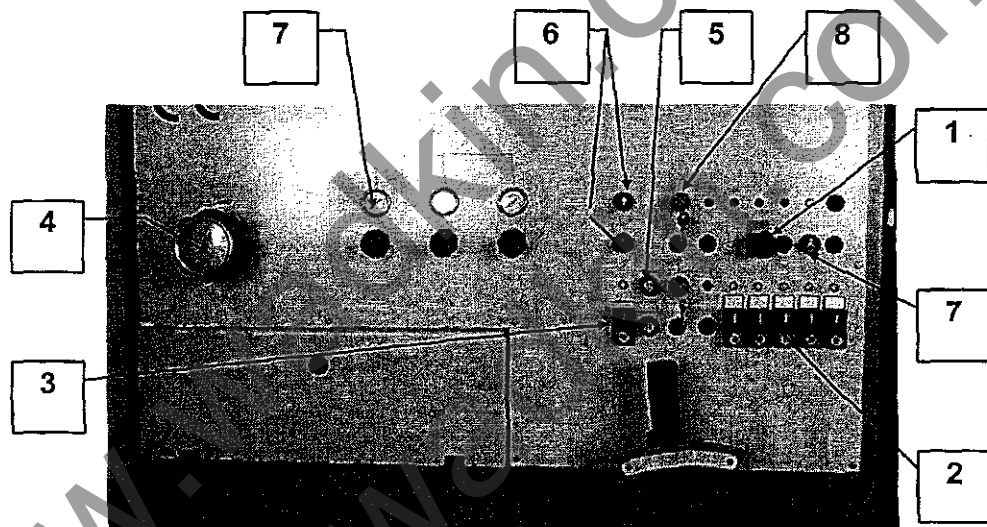

Figure 4.2.1

#### Emergency Stop (1)

Emergency stop button shuts down machine operation when depressed. Must be unlocked to reset.

Emergency stop buttons are also located at other points on the machine. One at outfeed end of machine. One at middle front of machine.

#### Spindle Start/Stop (2)

Each spindle has a start/stop button with indicator lamp. These enable spindles to be started and stopped independently. All spindles must be running before feed system will function.

### **Feed Stop/Start (3)**

Start/stop button with indicator lamp which controls the operation of the feed rolls.

### **Feed Speed (4)**

Controls the speed of the feed through the machine. Must be adjusted only when the feed is operating.

### **Inch Forward/Reverse (5)**

Two buttons enable the feed to be inched forward or backwards - for setting-up or other maintenance purposes.

With keyswitch in forward position feed can be inched forward only.

With keyswitch in reverse position spindles will automatically stop before reverse can be used.

### **Beam Raise/Lower (6)**

Two buttons enable the beam to be raised or lowered within predetermined limits.

Similar buttons are also on the local control panel located beneath the first top head. (see Figure 4.2.2).

### **Air Pressure Regulators/Gauges (7)**

Set the feedroll pressures.

### **Enclosure Override (8)**

Two-position keyswitch which enables the machine drives to operate when the enclosure is raised - for setting-up and other maintenance purposes.

With safety cover open, only inch forward is operable.

### **Spindle Head Brake Release (9)**

Releases the spindle brakes to enable free rotation of the spindles for changing cutter blocks, belts, etc; Indicator lamp shows when brakes released.

Note: Do not leave brakes in released position for extended periods of time.

#### 4.2.2 Machine Front Face

The machine front face controls are located beneath the first top head and consist of a number of buttons, switches and indicators (see Figure 4.2.2).

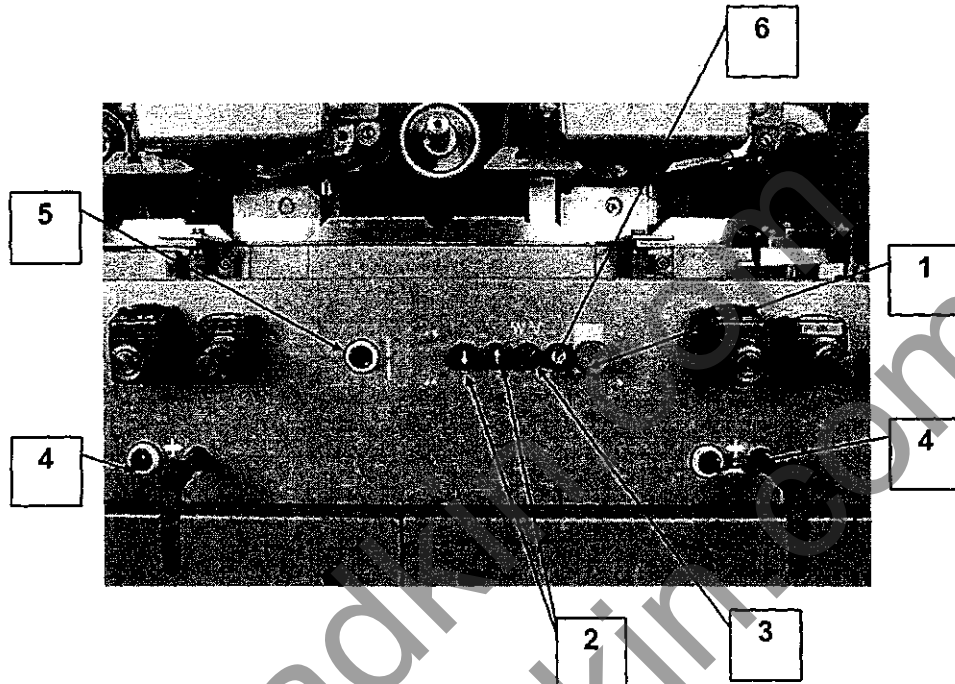

Figure 4.2.2

##### Emergency Stop (1)

Emergency stop button shuts down machine operation when depressed. Must be unlocked to reset.

##### Beam Raise/Lower (2)

Two buttons enable the beam to raised or lowered within predetermined limits.

##### Beam rise and fall Speed Control (3)

Switch controls the speed of the beam raise/lower movements.

'Fast' position is used for rapid movement of feed rolls and/or both top heads.

'Slow' position is used to accurately position either or both top heads.

##### Top Head Clutches (4)

Two switches one for each top head, engage/disengage clutches on top heads - for setting-up and other maintenance purposes.

**Clamp On/Off (5)**

This switch enables the axial movements of all the spindles to be pneumatically clamped/unclamped.

**Inch Forward (6)**

Button enables the feed to be inched forward - for setting-up and other maintenance purposes.

www.wadkin.com  
info@wadkin.com

## 5 SETTING-UP THE MACHINE

---

### 5.1 General

This Section describes the procedures to set-up a six-spindle Model K23/K25 machine for a planing operation.

Setting-up comprises setting tool spindles to basic positions relative to the table and the fence using a straight edge, and setting feed roll height.

To achieve a good product, the tool must be adjusted very accurately to the table or fence **after** the tool.

The basic procedure for setting-up all cutting tools (except where specified differently in this Section) is as follows:

- 1 Place the straight edge on the table or against the fence **after** the tool and hold in position.
- 2 Rotate the tool by hand in the opposite direction of the cut.
- 3 Adjust the position of the tool until a **cutting edge** of the tool touches the straight edge.

To eliminate spindle backlash, always move the bottom head and edge spindles in the direction of the workpiece to their final positions, but move the top head and feed rolls in an upward direction.

- 4 Ensure both spindle movements are locked.

#### 5.1.1 Preparation

Before beginning the setting-up procedure carry out the following checks:

- 1 Cutter blocks are securely fitted (see Section 5.1.2).
- 2 Adequate working space is provided and lighting is available.
- 3 Proper protective equipment (goggles, ear defenders, face mask, etc) is available and employed if required.
- 4 Area around the machine is clean and free of wood refuse.
- 5 Machine spindles and feed rolls are stationary and the machine is electrically isolated.

Equipment required:

- 1 Straight edge.
- 2 Standard tool kit.

### 5.1.2 Remove/Refit Cutter Block in Spindle (Figure 5.1.2)

**WARNING:**

**ENSURE THAT THE MACHINE IS ELECTRICALLY ISOLATED (EMERGENCY STOP ACTIVATED) BEFORE PROCEEDING.**

*Notes:*

*All spindles have right-hand threads.*

*Do not strike any component; do not use a box or extension spanner.*

- 1 Open or remove any guards to permit easy access to the cutter block.
- 2 Using a combination spanner, unscrew the spindle nut from the spindle by locating the spanner on the hexagon (1) of the spindle and the two flat faces of the cutter block locknut (2), (unscrew counterclockwise).
- 3 Before refitting the cutter block, carefully clean the spindle and the cutter block.
- 4 Locate the cutter block on the spindle and tighten (clockwise) using the combination spanner.

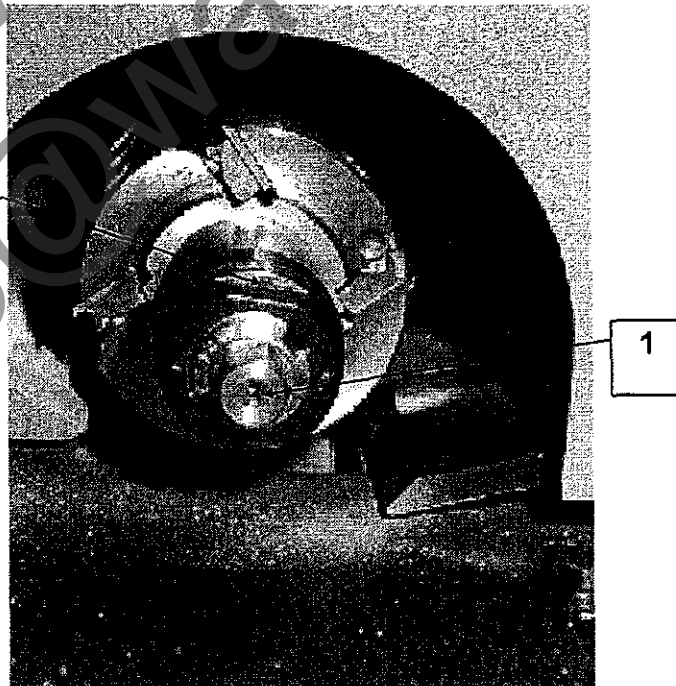

Figure 5.1.2



## 5.2 Setting First Bottom Head (Figure 5.2)

Setting the first bottom head involves a radial (vertical) and axial (horizontal) adjustment. It sets the cutter block level with the outfeed side bed of the head, the actual cut size being set by the infeed table adjustment (see a later procedure); it also sets the edge reference knives (when fitted).

### **WARNING:**

**ENSURE THAT THE MACHINE IS ELECTRICALLY ISOLATED (EMERGENCY STOP ACTIVATED) BEFORE PROCEEDING.**

### Vertical Setting

- 1 Open or remove any guards to permit easy access and ensure that the bottom head outfeed side bed is clear.
- 2 Place the straight edge (1) on the outfeed side bed extending over the bottom head cutter block.
- 3 Release spindle barrel clamp (2).
- 4 Turn the cutter block by hand counterclockwise and adjust screw (3) until a cutting edge of the cutter block **just touches** the straight edge. The final movement of the spindle should be **towards** the workpiece.
- 5 Lock clamp (2).
- 6 Check that adjustment is correct **across whole width** of the cutter block.

### Horizontal Setting

This adjustment is used only when the machine is employing an edge reference block.

- 7 Release spindle barrel clamp (2).
- 8 Place the straight edge (1) along the reference fence (4) extending over the bottom head cutter block.
- 9 Adjust eccentric pin (5) until the edge reference knives **just touch** the straight edge. The final movement of the spindle should be **towards** the workpiece.
- 10 Lock clamp (2).
- 11 Refit/replace guards.

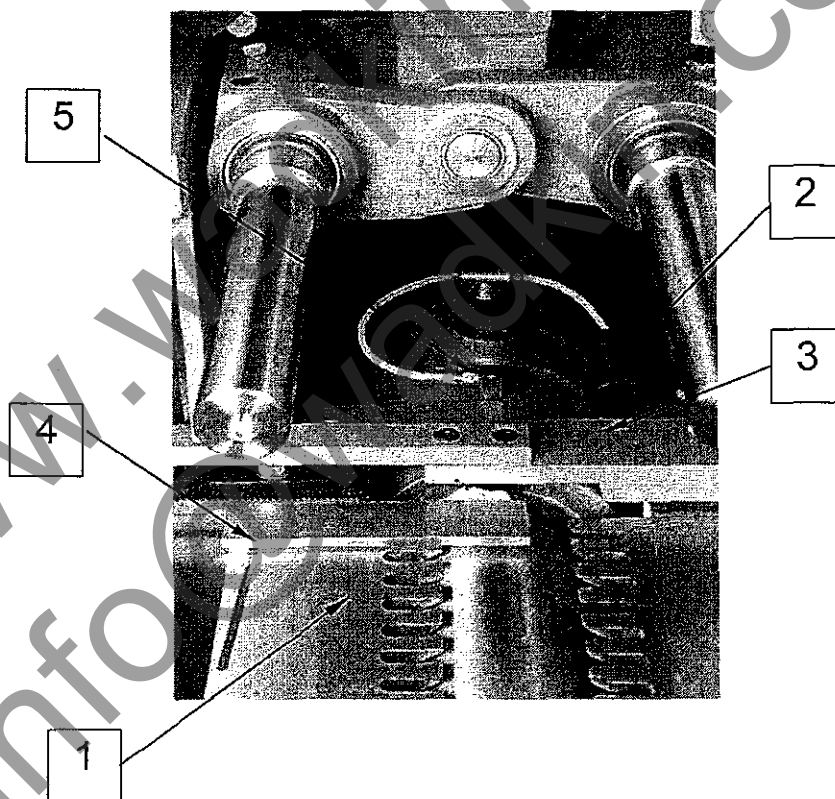

Figure 5.2

### 5.3 Setting Fence Side Head (Figure 5.3)

Setting the fence side head involves a radial (horizontal) and axial (vertical) adjustment. The horizontal adjustment sets the cutter block in line with the outfeed side of the fence. The actual cut will be set by the infeed fence adjustment (see a later procedure). The vertical adjustment sets the position of the side head profile, or if planing, the amount of knife below the bed.

**WARNING:**

**ENSURE THAT THE MACHINE IS ELECTRICALLY ISOLATED (EMERGENCY STOP ACTIVATED) BEFORE PROCEEDING.**

**Vertical Setting**

- 1 Unclamp the pneumatic lock on the head ((1) on Figure 4.2.2).
- 2 Using the crank handle adjust shaft (6) until the spindle flange is the required amount below the level of the bed.  
  
Clockwise rotation of the crank handle raises the cutter block (giving a negative count on the digital indicator), counterclockwise rotation lowers it. The final movement of the spindle should be upwards.
- 3 Clamp the pneumatic lock on the head ((1) on Figure 4.2.2).
- 4 Refit/replace guards.

**Horizontal Setting**

- 5 Open or remove any guards to permit easy access and ensure that the outfeed side of fence is clean.
- 6 Place the straight edge (1) against the outfeed fence extending over the fence side head cutter block.
- 7 Release locking handle (2).
- 8 Turn the cutter block by hand clockwise and using the crank handle adjust shaft (3) until a cutting edge of the cutter block **just touches** the straight edge. The final movement of the spindle should be **towards** the workpiece.  
  
Clockwise rotation of the crank handle moves the cutter block away from the fence (giving a positive count on the digital indicator), counterclockwise rotation moves it towards the fence.
- 9 Lock handle (2).

- 10 Position the outfeed fence nose piece (4) by slackening the locking screw (5), located behind the fence, and then positioning the nose piece 3 to 5mm from the cutter block.
- 11 Retighten screw (5).

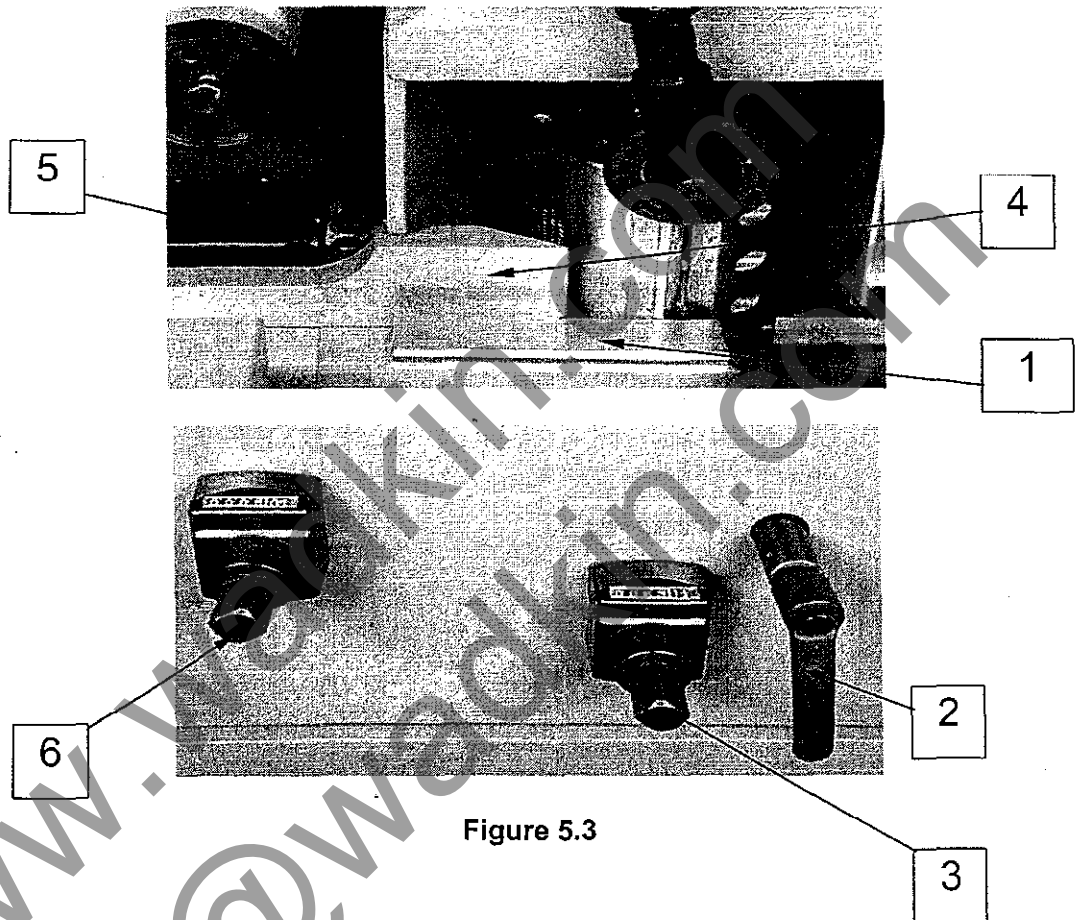

Figure 5.3

## 5.4 Setting Near Side Head (Figure 5.4)

Setting the near side head involves a radial (horizontal) and axial (vertical) adjustment. It datums the cutter block to the width of the product and also sets the position of the side head profile, or if planing, the amount of knife below the bed. This procedure also includes the setting of the near side head chipbreaker, double side roller pressures, and the near side head pad pressure.

### **WARNING:**

**ENSURE THAT THE MACHINE IS ELECTRICALLY ISOLATED (EMERGENCY STOP ACTIVATED) BEFORE PROCEEDING.**

### Vertical Setting

- 1 Unclamp the pneumatic lock on the head ((1) on Figure 4.2.2).
- 2 Using the crank handle, adjust shaft (4) until the cutter block is the required depth below the level of the bed.  
  
Clockwise rotation of the crank handle raises the cutter block (giving a negative count on the digital indicator), counterclockwise rotation lowers it. The final movement of the spindle should be e.
- 3 Clamp the pneumatic lock on the head ((1) on Figure 4.2.2).

### Horizontal Setting

- 4 Open or remove any guards to permit easy access and ensure that the near side head outfeed bed is clear.
- 5 Release locking handle (1).
- 6 Set the dial indicator switch (2) to the upper position (cutter block radius) and using the crank handle adjust shaft (3) to set the indicator to the radius of the fitted cutter block.
- 7 Set the dial indicator switch (2) to the lower position and using the crank handle adjust shaft (3) until the indicator registers the desired width of the product.  
(Ensure that feed rollers opposite nearside head do not foul)  
  
Clockwise rotation of the crank handle moves the cutter block towards the fence (giving a negative count on the digital indicator), counterclockwise rotation moves it away from the fence. The final movement of the spindle should be **towards** the workpiece.
- 8 Lock handle (1).

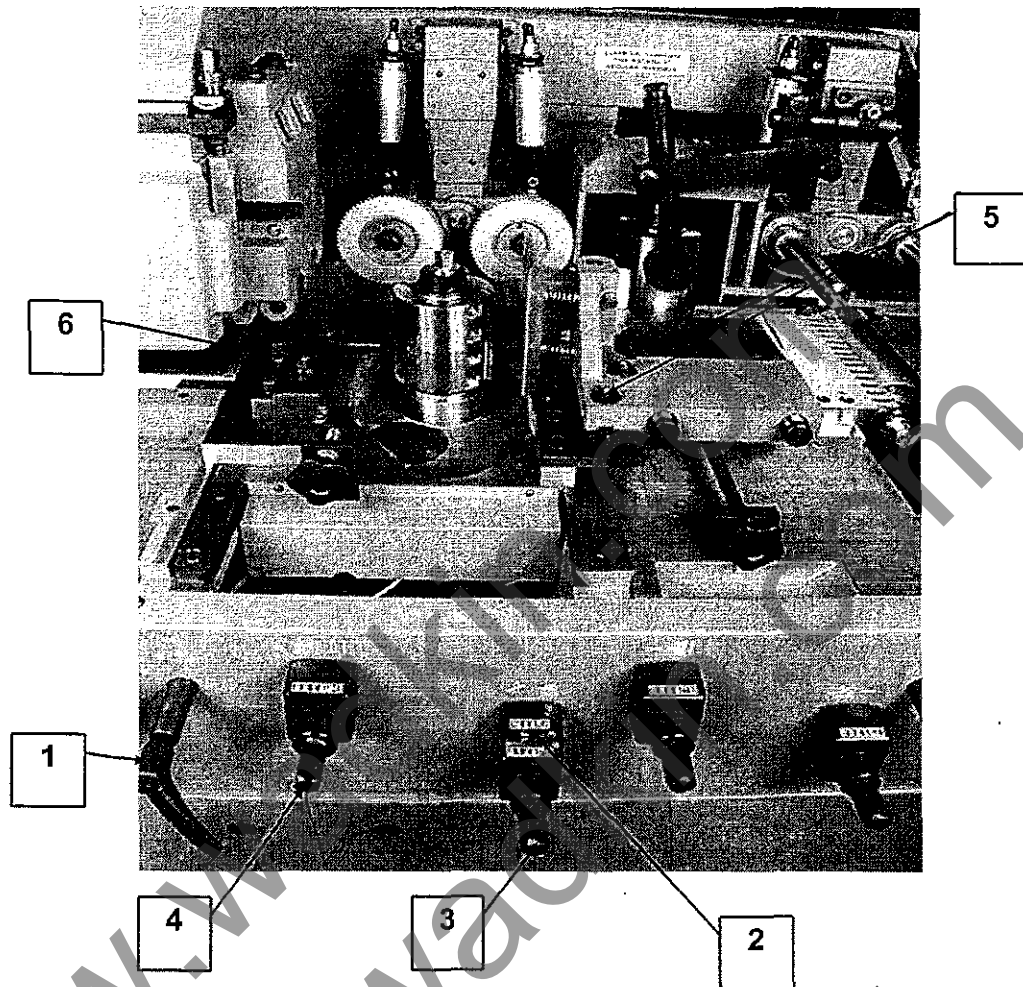

Figure 5.4

#### Chipbreaker and Pad Pressure Setting

- 10 Slacken bolts (5) and move the chipbreaker forward until the front face of the chipbreaker shoe is in line with the minimum cutting circle of the cutters.
- 11 Tighten bolts (5).
- 12 Slacken nut (6) and place a straight edge against the face of the pad pressure extending over the near side head cutter block.
- 13 Turn the cutter block by hand clockwise and adjust the pad pressure until a cutting edge of the cutter block **just touches** the straight edge. The final movement of the pad pressure should be **towards** the workpiece. (A final adjustment of this setting can be undertaken during pre-operation checks (see Section 6.1.2)).

Check that the tip of the pad pressure shoe is between 3 and 5mm from the tip of the cutter.

- 14 Tighten nut (6).
- 15 Refit/replace guards.

[www.wadkin.com](http://www.wadkin.com)  
[info@wadkin.com](mailto:info@wadkin.com)

## 5.5 Setting First Top Head (Figure 5.5)

Setting the first top head involves a radial (vertical) and axial (horizontal) adjustment. It can also datum the cutter block to the height of the product.

The vertical adjustment can be accomplished either powered through the rise and fall beam, or by direct manual adjustment.

(The master stops must be released to enable the powered adjustment to be used.)

### WARNING:

**ENSURE THAT THE MACHINE IS ELECTRICALLY ISOLATED (EMERGENCY STOP ACTIVATED) BEFORE PROCEEDING.**

### Vertical Setting

- 1 Open or remove any guards to permit easy access and ensure that the first top head outfeed bed is clear.
- 2 Reset the emergency stop.
- 3 Operate switch (1) to engage the clutch **on the first top head only**.
- 4 Release locking handle (2).

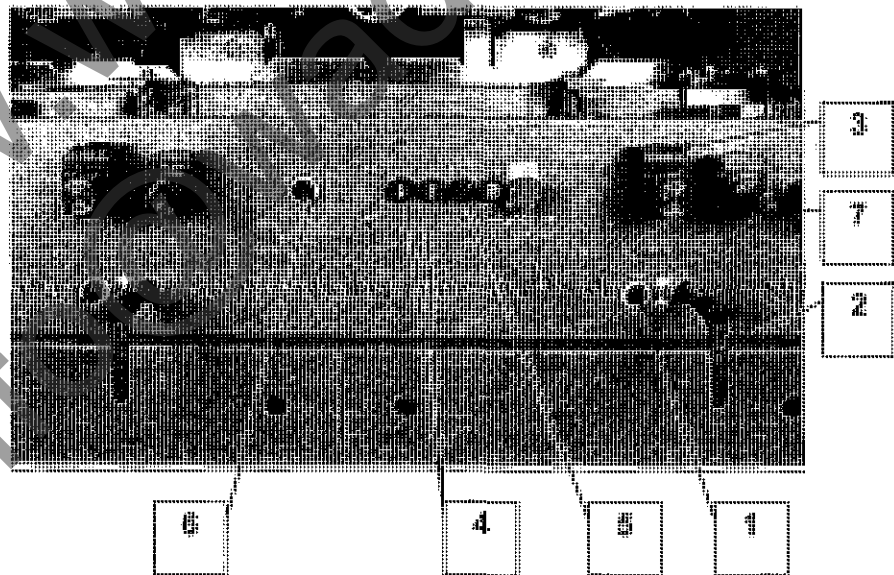

Figure 5.5

- 5 Set the dial indicator switch (3) to the upper position (cutter block radius) and using the raise/lower buttons (4) set the indicator to the radius of the fitted cutter block.



- 6 Set the dial indicator switch (3) to the lower position and using the raise/lower buttons (4) set the height of the cutter block until the indicator registers the desired height of the product. The final movement of the spindle should be **away from** the workpiece.

*Note:*

*The beam movement speed control switch (5) enables the speed of movement of the beam to be set at fast or slow (for fine adjustment).*

- 7 A crank handle can be fitted to the shaft, to enable fine adjustment of the height of the cutter block to be carried out manually if preferred.

**WARNING:**

**ENSURE THAT THE MACHINE IS ELECTRICALLY ISOLATED (EMERGENCY STOP ACTIVATED) BEFORE PROCEEDING WITH MANUAL ADJUSTMENT.**

- 8 Lock handle (2).

**Horizontal Setting**

- 9 Release pneumatic clamp (6).
- 10 Using the crank handle, adjust shaft (7) until the spindle flange is the required distance behind the fence line. The final movement of the spindle should be **towards** the workpiece.
- 11 Lock pneumatic clamp (6).
- 12 Refit/replace guards.

## 5.6 First Top Head Pad Pressure and Chipbreaker (Figure 5.6)

This procedure sets the pad pressure and chipbreaker to the base cutting circle of the first top head cutter block.

- 1 Open or remove any guards to permit easy access and ensure that the first top head outfeed bed is clear.
- 2 Ensure that the face of the pad (1) is clean.
- 3 Rotate the handwheel (2) until the dial indicator (3) registers the radius of the fitted cutter block.
- 4 Slacken locknut (4) and position the pad nose 5mm from the cutter block.
- 5 Position the pad laterally over the bed to suit the product width and tighten locknut (4). Ensure that the pad is in front of the fence line.
- 6 Check that the chipbreaker shoes (5) are compatible with the diameter of the cutter block. (The top head is supplied with different lengths of chipbreaker shoe to suit various diameters of cutter block. Each shoe is secured by two countersunk screws through the bottom face).  
  
The shoe should be as close as possible to the maximum cutting circle while also allowing only safe chipbreaker operation.
- 7 Slacken locknuts (6) and turn the adjusting screw (7) until the dial indicator (8) registers the radius of the fitted cutter block.
- 8 Tighten locknuts (6).
- 9 Refit/replace guards.

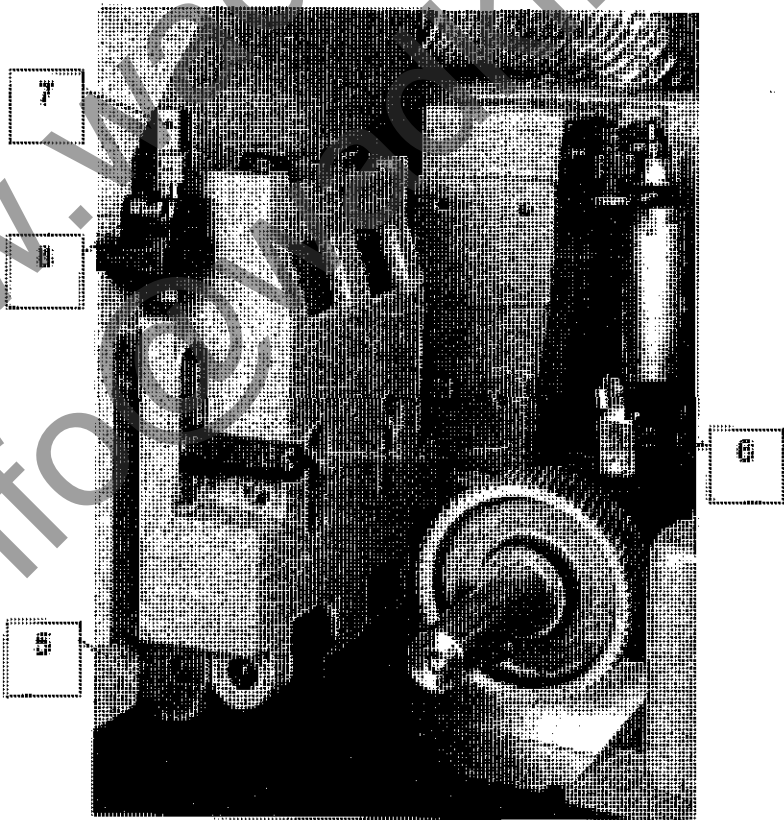
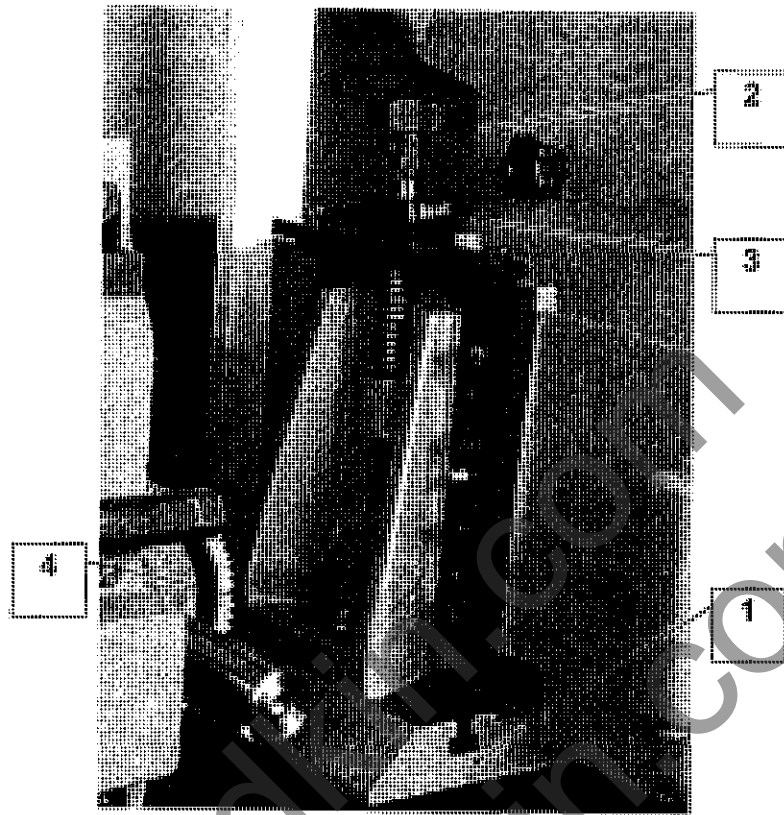

Figure 5.6

## **5.7 Setting Second Top Head, Pad Pressure and Chipbreaker (Figures 5.5 and 5.6)**

These procedures are identical to the first top head, pad pressure and chipbreaker procedures covered in Sections 5.5 and 5.6.

[www.wadkin.com](http://www.wadkin.com)  
[info@wadkin.com](mailto:info@wadkin.com)

## 5.8 Setting Second Bottom Head (Figure 5.8)

When planing or moulding, the outfeed side bed plate of the second bottom head is shimmed to be nominally 0.5mm above bed normal level.

### Horizontal Setting

- 1 Unclamp the pneumatic lock on the head ((1) on Figure 4.2.2).
- 2 Using the crank handle, adjust shaft (4) until the cutterblock is the required distance behind the fence line. The final movement of the spindle should be **towards** the workpiece.
- 3 Clamp the pneumatic lock on the head ((1) on Figure 4.2.2).
- 4 Refit/replace guards.
- 5 **Check that bedplate clamps (3) are tight and the bedplate is positioned as described in Step 10.**

### Vertical Setting

- 6 Open or remove any guards to permit easy access and ensure that the bottom head outfeed side bed is clear.
- 7 Place a straight edge on the outfeed side bed extending over the bottom head cutter block.
- 8 Release locking handle (1).
- 9 Turn the cutter block by hand counterclockwise and using the crank handle, adjust shaft (2) until a cutting edge of the cutter block **just touches** the straight edge. The final movement of the crank handle should be **towards** the workpiece.
- 10 Release bedplate clamps (3) and position the bedplates to be between 3 and 5mm from a cutting edge on the cutter block.
- 11 Retighten clamps (3).
- 12 Lock handle (1).
- 13 Check that adjustment is correct **across whole width** of the cutter block.

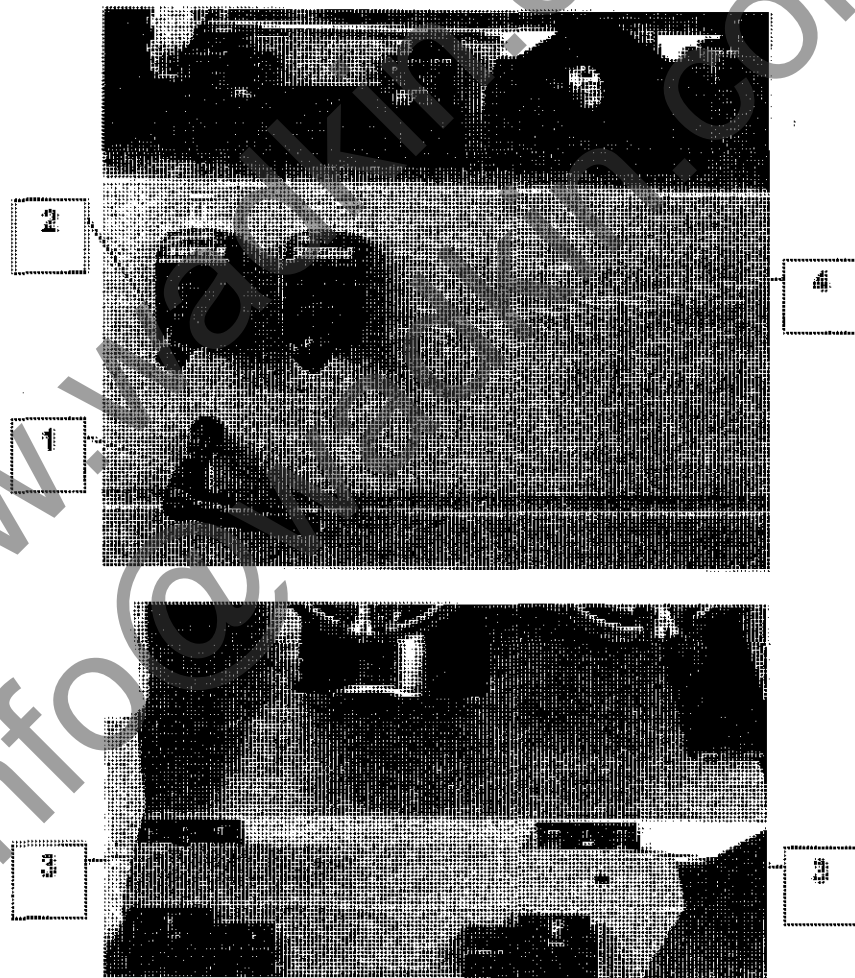

Figure 5.8

## 5.9 Setting the Feed Rolls (Figures 5.9.1, 5.9.2 and 5.9.3)

The throughfeed, gearbox-driven top feed rolls are mounted on the beam and pressure is exerted via pneumatic cylinders (with additional manual adjustment on feed rolls after the first top head). The feed rolls are all shaft-mounted, except opposite the nearside head, where they are flange mounted

Initial setting of the feed rolls is made through the beam control setting (beam raise/lower buttons on the machine control panel). This setting should be the height of the finished product.

Maximum traction over the full width of the product is achieved by using spacers (flange-mounted feed rolls) and by positioning of rolls at points along the shaft (shaft-mounted feed rolls). To suit the width of the product being machined.

Feed rolls shall be fitted not less than 4mm from a fence.

### Positioning Shaft-Mounted Feed Rolls (Figure 5.9.1)

- 1 Ensure that shaft is clean.
- 2 Slacken set screw (1).
- 3 Position feed roll(s) to suit product width.
- 4 Tighten set screw (1).

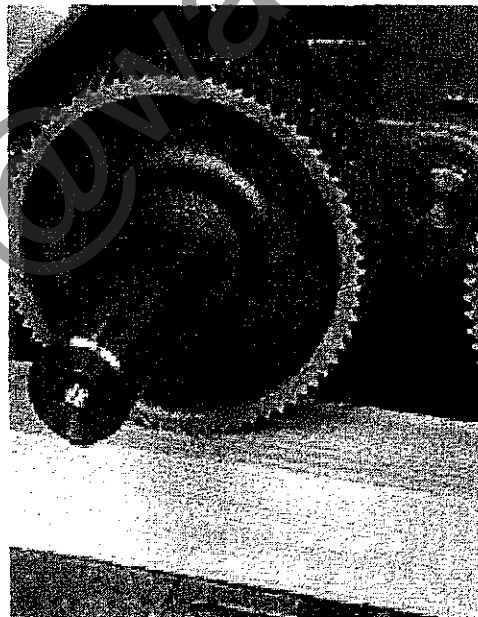

Figure 5.9.1

**Positioning Flange-Mounted Feed Rolls (Figure 5.9.2)**

- 1 Slacken the draw bolt (1), remove the 'C' washer (2) and withdraw the bolt.
- 2 Load spacers and feed rolls over the draw bolt engaging drive pins of spacers and feed rolls into opposite holes.

The combination of feed rolls and spacers will depend upon the product width.

- 3 Hold the assembly against the drive flange and screw in draw bolt until close to the face of the end feed roll.
- 4 Slot the 'C' washer (2) over the draw bolt (1) and tighten the draw bolt.



**Figure 5.9.2**



**Setting Feed Rolls after the Top Heads (Figure 5.9.3)**

This procedure is undertaken **after the initial beam height setting**, and the setting should be approximately 3mm less than the finished product height.

- 1      Slacken nut (1).
- 2      Rotate handwheel (2) to adjust the height of the feed roll from the bed to approximately 3mm less than the height of the finished product.
- 3      Tighten nut (1).
- 4      Check height of the feed roll from the bed and reset if necessary.

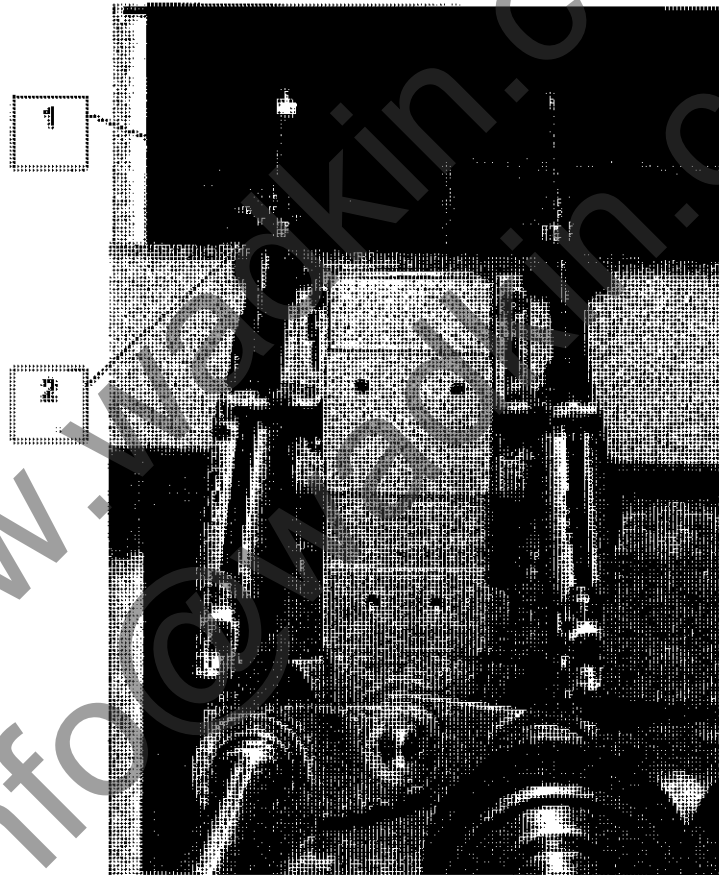

**Figure 5.9.3**

### Setting Top Roller Pressure (Figure 5.9.4)

This procedure is undertaken **after the initial beam height setting**, using, if possible, a piece of timber the same thickness as the finished product.

- 1 Place the timber beneath the top roller assembly.
- 2 Slacken bolt (1) and position the roller as close as possible to the cutter block
- 3 Slacken bolt (2) and move the roller laterally to be central to the cutter block.
- 4 Slacken bolt (3) and lower the roller until it touches the timber.
- 5 Rotate screw (4) to increase or decrease pressure on the roller.
- 6 Tighten bolts (1), (2) and (3).

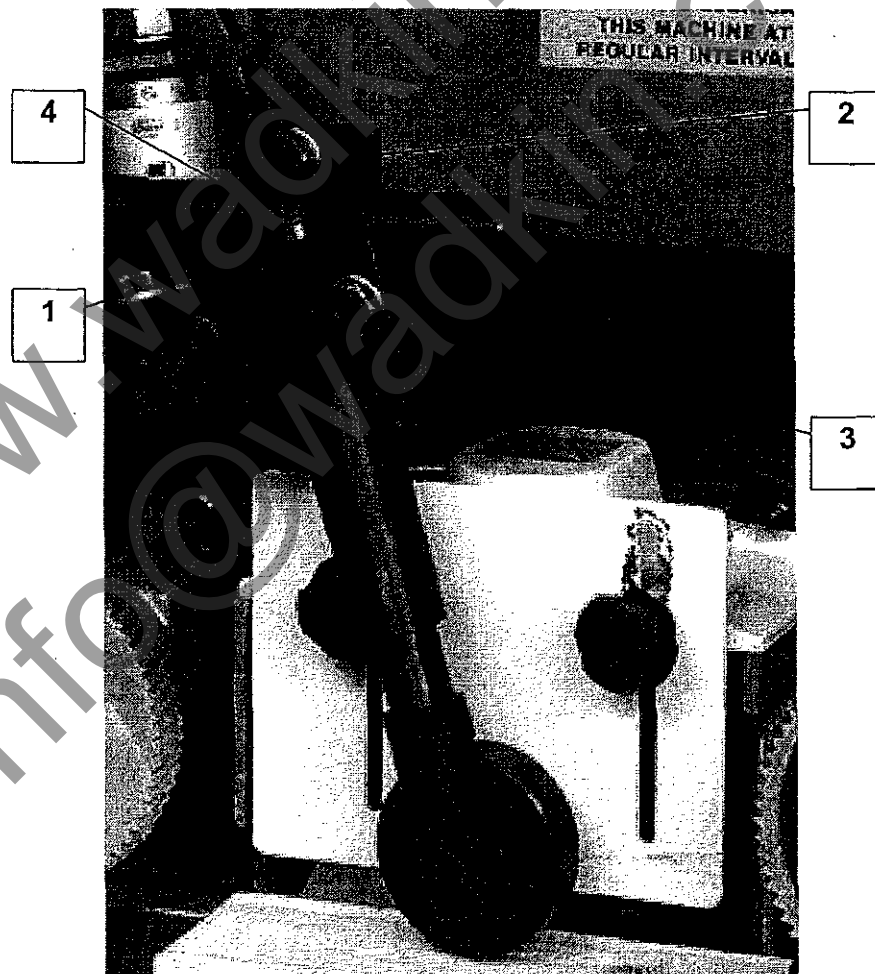

Figure 5.9.4

## 5. 10 Infeed Table and Fence Adjustment (Figure 5.10)

The height of the infeed table determines the cut to the first bottom head. There is a maximum adjustment of 10mm. When the adjustment is zero, the infeed table is level with the table after the first bottom head.

Infeed fence adjustment determines the cut at the first fence side edge. There is a maximum adjustment of 10mm.

### Table Adjustment

- 1 Rotate knurled handle (1) counterclockwise to release locking mechanism.
- 2 Position handle until the indicator (2) reads the required cut depth.
- 3 Rotate handle (1) clockwise to lock the table.

### Infeed Fence Adjustment

- 1 Unlock both handles (3) to enable fence to be adjusted.
- 2 Using handle (4) adjust the infeed fence until the scale (5) reads the required measurement.
- 3 Relock handles (3) to lock the infeed fence.



Figure 5.10

## 6 OPERATION

---

### 6.1 General

This Section gives a typical operating sequence for a Model K23/K25 machine using the controls described in Section 4 and the basic set-up procedures described in Section 5.

It should be noted that the sequence is typical only - the use of machine controls in conjunction with the setting-up procedures vary depending upon the features of the machine and also the process it is to undertake.

Users are expected to establish operating procedures which comply with local requirements and practices.

#### 6.1.1 Pre-operation Checks

Undertake all the pre-operation checks detailed in Section 4.1.1.

#### 6.1.2 Setting Controls and Adjustments

- 1 Close the electrical supply isolator situated on the electrical cabinet, and ensure the compressed air supply is available.
- 2 Ensure all master stop buttons are released.
- 3 Position the near side head, chipbreaker and side guide to the width of the finished product (see Section 5.4).
- 4 Set the second top head to the height of the finished product (see Section 5.7).
- 5 Lower the beam to the height of the finished product (see Section 5.9).

**Before continuing, check all guards and check that the dust extraction system is switched on and working properly.**

- 6 With the spindle brakes released, carefully rotate all cutter blocks by hand to ensure free rotation. (one master stop button should be activated during this procedure).
- 7 With the enclosure door open, turn the 'enclosure override' keyswitch to door open, and the 'inch feed' keyswitch to forward.

- 8 Start all spindles.

During the set-up procedure the main feed is inoperative; only the inch control forward is enabled allowing the workpiece to move forward a short distance at a time, each movement requiring a press of the button.

- 9 Using the 'inch forward' control pass a 'test piece' timber through the machine and check the dimensions for specification and the quality of finish.

**WARNING:**

**NO ADJUSTMENTS SHOULD BE MADE WITH SAFETY COVER OPEN AND SPINDLES RUNNING.**

- 10 Repeat Step 9 until the 'test piece' timber meets all dimensional and quality requirements.

- 11 Set the machine to operate in production mode by setting the 'enclosure override' keyswitch to door closed, starting main feed and setting feed speed to the required feed rate.

The machine is now ready for production operation.

www.wadkin.com  
info@wadkin.com

## 7 MAINTENANCE

---

### 7.1 General

This Section covers scheduled maintenance of the machine and also some basic fault-finding procedures.

Scheduled maintenance comprises the maintenance necessary, at regular intervals, to maintain the machine in good working order.

Unscheduled maintenance is that work necessary to replace or repair worn, unserviceable or damaged components.

Scheduled maintenance can normally be undertaken by a competent, but not necessarily specialised person (operator); unscheduled maintenance must be undertaken by an engineer experienced on this type of equipment and equipped with special tools.

### 7.2 Scheduled Maintenance

The following schedule, when undertaken, should be recorded in a maintenance log.

Equipment required:

- 1 Compressed air gun.
- 2 Standard tool kit.
- 3 Lubricants as detailed.
- 4 Grease gun.
- 5 Oil hand pump.
- 6 Replacement parts as necessary.

#### 7.2.1 Daily

**WARNING:**

**ENSURE THAT THE MACHINE IS ELECTRICALLY AND PNEUMATICALLY ISOLATED BEFORE UNDERTAKING ANY OF THE FOLLOWING TASKS.**

**LOCKABLE ELECTRICAL ISOLATORS ARE SUPPLIED WITH THIS MACHINERY TO ALLOW STANDARD LOCK-OUT & TAG OUT PROCEDURES TO BE FOLLOWED PRIOR TO UNDERTAKING ANY MAINTENANCE TASKS.**

- 1 Clean the machine using a compressed air gun taking care not to direct the air jet directly on to spindles, shafts, bearing housings, etc.

Clean the spindles and cutter block collars and lightly lubricate with hydraulic oil (see the lubrication chart at the end of this Section for oil types).

*Note:*

*The amount of lubrication and the frequency of application depends upon the type of wood being processed and speed of throughput. This requirement is based on experience and could well be necessary a number of times a day. A tap is fitted to the oil pump to preset the flow rate.*

- 3 Carry out a visual check of the machine and the surrounding area to check for any obvious signs of damage, wear, etc., and to ensure safe working conditions exist.

**7.2.2 Monthly**

- 1 If machine is fitted with centralised lubrication:  
Apply hydraulic oil using a hand pump via the lubrication points on the front of the machine (see the lubrication chart at the end of this Section for oil types).

- 2 If the machine is manually lubricated:  
Grease the machine slideways and handscrew mechanisms with lithium grease using a grease gun via the grease nipples on the front of the machine.  
Grease spindle barrels, top head chipbreaker, pad pressures and feedroll shafts.  
Grease Universal Head Rise & Fall, In & Out.  
At the rear of the machine grease all rise & fall screws and slides & gib strips.

(See the lubrication chart at the end of this Section for grease types).

**7.2.3 Three-Monthly**

- 1 Remove covers from all spindle drive belts (top, bottom, fence and side heads) and check the belt tension.
- 2 Check the main/infeed/outfeed toothed drive belts for wear or cracking. (If replacement is necessary, refer to the Parts Manual for ref. number).
- 3 Remove the cowls from the electric drive motors and clean the motor fans; check for signs of overheating or excessive end-float of the motors.

### 7.3 **Unscheduled Maintenance**

Unscheduled maintenance is that work necessary to replace or repair worn, unserviceable or damaged components.

Generally, following any procedure covered in this section, a set-up procedure will need to be undertaken (see Section 5) before the machine is put back into service.

This section covers checks and replacement procedures in isolation. There will be times, depending upon the work undertaken, where many of these procedures will be carried out sequentially.

**WARNING: ENSURE THAT THE MACHINE IS ELECTRICALLY AND PNEUMATICALLY ISOLATED BEFORE UNDERTAKING ANY OF THE FOLLOWING TASKS.**

**ENSURE THAT PROPER PROTECTIVE CLOTHING IS USED THROUGHOUT THESE TASKS.**

**LOCKABLE ELECTRICAL ISOLATORS ARE SUPPLIED WITH THIS MACHINERY TO ALLOW STANDARD LOCK-OUT & TAG OUT PROCEDURES TO BE FOLLOWED PRIOR TO UNDERTAKING ANY MAINTENANCE TASKS.**



### 7.3.1 Removal of K23/K25 Horizontal Spindles (Top and Second Bottom) (Figure 7.3.1.)

1. Remove the cutter block from the spindle ensuring that the area is clean and free of resin where the spindle barrel is exposed.
2. Remove all front and rear safety covers to enable access to all horizontal heads.
3. Remove all tin covers to allow access to the drive belts.
4. Loosen the four M12 nuts ( 1 ) which secure the motor to the motor mounting bracket.
5. Loosen the M10 locking nut and manually adjust the tensioning screw ( 2 ) to allow the motor to be elevated.
6. Raise the motor until the belt is no longer under load.
7. Tighten the four nuts to hold the motor in place.
8. Remove the belt.
9. Loosen the cap screws securing the adjustable nut ( 3 ) to the spindle end cap, remove the M10 bolt ( 4 ) and remove the nut.
10. Release the pneumatic spindle locking clamp (refer to (5) on Figure 4.2.2.)
11. Draw the spindle out towards the rear of the machine with the aid of a film of oil (see the lubrication chart Figure 7.5.2.).
12. To re-assemble the spindle simply reverse the above procedure remembering to follow the belt tensioning information documented in (Figure 7.3.4.)

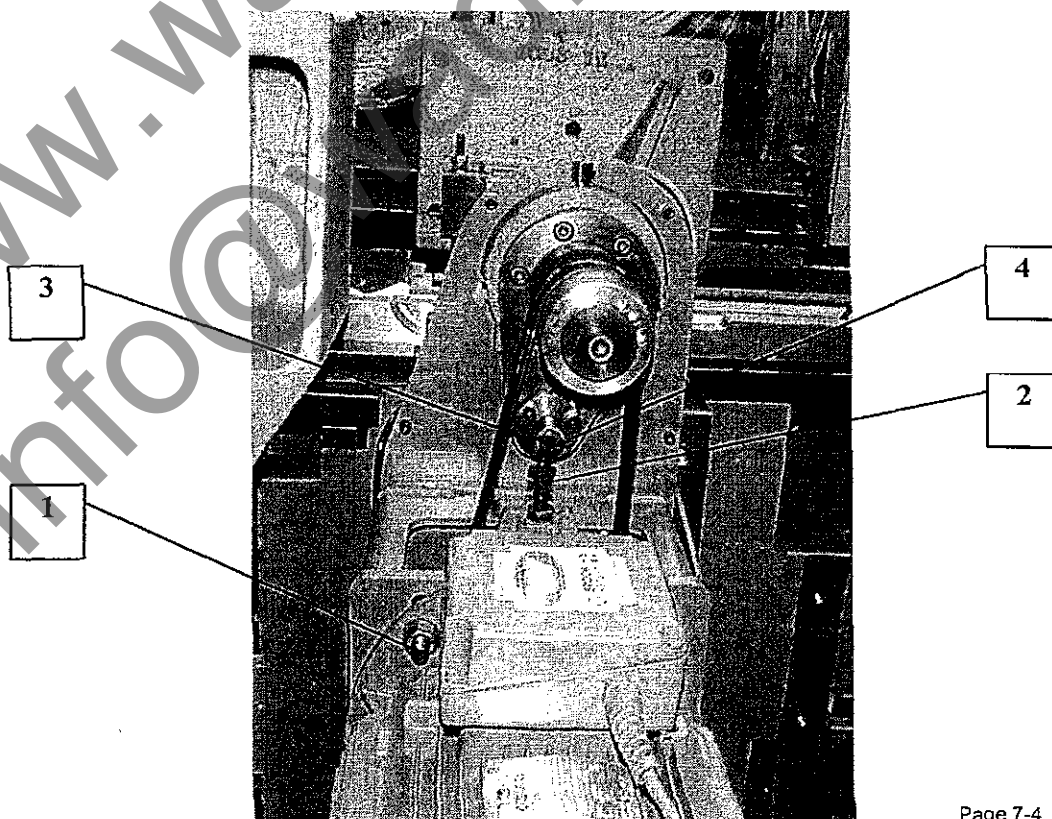

Figure 7.3.1

### 7.3.2 Removal of K23/K25 First Bottom Head Spindle (Figure 7.3.2.)

1. Remove the cutter block and edge reference cutter from the spindle ensuring that the area is clean and free of resin where the spindle barrel is exposed.
2. Remove all front and rear safety covers to enable access to the first bottom head spindle.
3. Remove all tin covers to allow access to the drive belt.
4. Loosen the four M12 nuts which secure the motor to the motor mounting bracket.
5. Loosen the M10 locking nut and unscrew the tensioning bolt to allow the motor to be elevated.
6. Raise the motor until the belt is no longer under load.
7. Tighten the four nuts to hold the motor into position.
8. Remove the belt.
9. Remove grub screw ( 1 ) that retains the eccentric pin.
10. Remove the eccentric pin ( 2 ).
11. Remove the M10 locknuts that retain the wormshaft ( 3 ).
12. Withdraw the wormshaft ( 4 ).
13. Release the barrel locking clamp ( 5 ).
14. Draw the spindle out towards the rear of the machine with the aid of a film of oil (see the lubrication chart Figure 7.5.2.).
15. To re-assemble the spindle simply reverse the above procedure remembering to follow the belt tensioning information documented in (Figure 7.3.4.)

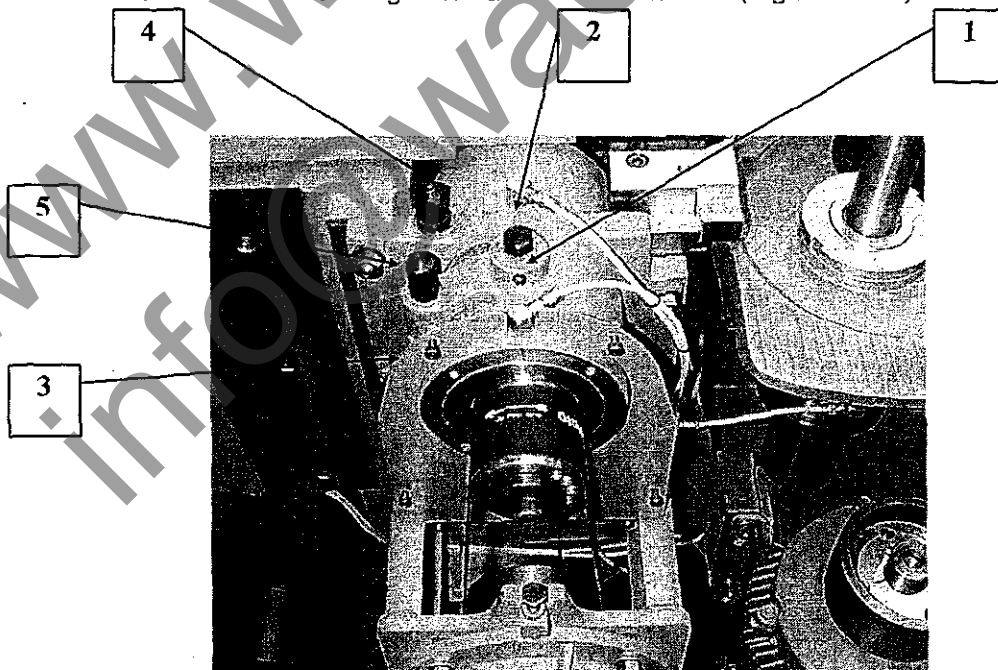

Figure 7.3.2

### 7.3.3 Removal of K23/K25 Vertical Spindles (Fence and Near Side Head) (Figure 7.3.3.)

*Please note that the shared drive belt for the vertical side heads is automatically tensioned by a gas spring.*

1. Remove the cutter block from the spindle ensuring that the area is clean and free of resin where the spindle barrel is exposed.
2. Remove all front and rear safety covers to enable access to the fence and near side head spindles.
3. Remove all tin covers to allow access to the drive belt.
4. Place the supplied lever tool (( 1 )Figure 7.3.3.) with the hole in the tool fitting over the idle belt roller pivot.
5. Applying force on the lever push the idle roller ( 2 ) back against the gas spring pressure and remove the belt. **Please note** to remember to allow the gas spring ( 3 ) to gently push the idle roller back after the belt is removed.
6. Loosen the M8 cap screws securing the adjustable nut to the spindle end cap, remove the M10 bolt and remove the nut and end cap respectively.
7. Help will now be needed!
8. Taking up a firm grip on the spindle.
9. Release the pneumatic spindle barrel clamp (refer to (5) figure 4.2.2).
10. Withdraw the spindle out upwards with the aid of a film of oil (see the lubrication chart Figure 7.5.2.).
14. To re-assemble the spindle simply reverse the above procedure remembering to follow the belt tensioning information documented in ( Figure 7.3.5).

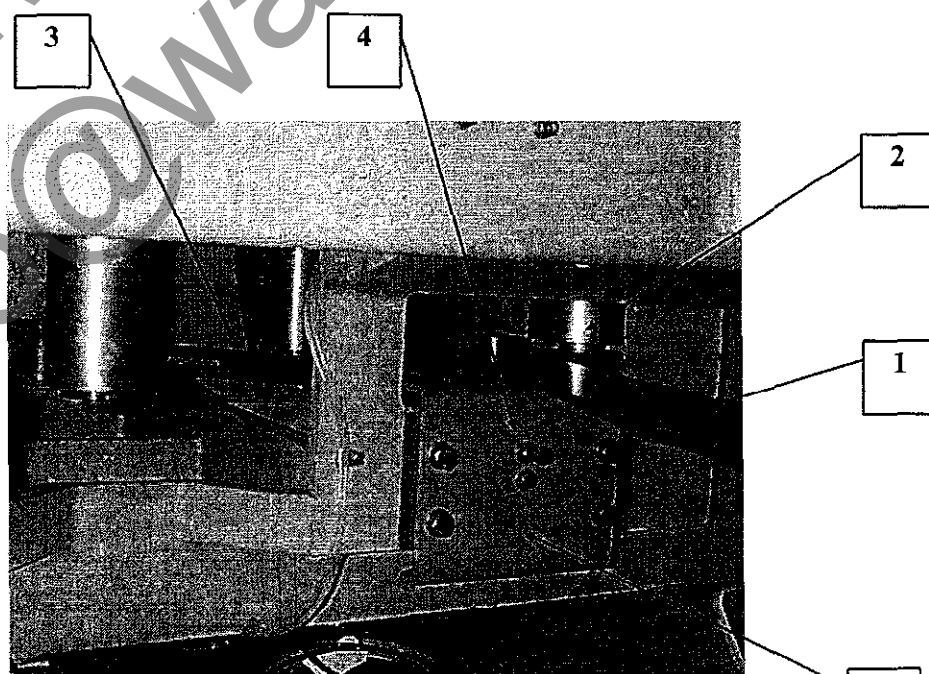

Figure 7.3.3

### 7.3.4 Replacing K23/K25 Top and Bottom Drive Belts (Figure 7.3.4.)

**Please note that the Top and Bottom heads follow the same procedure for the removal and tensioning of drive belts.**

1. Remove all front and rear safety covers to enable access to all horizontal heads.
2. Remove all tin covers to allow access to the drive belt.
3. Slacken the four M12 nuts which secure the motor to the motor mounting bracket to allow the motor to be raised.
4. Elevate the motor until the belt is not under load. Tighten the four M12 nuts to hold the motor in this position.
5. Check the drive belt for wear or cracking. Replace if necessary and replace with the **correct** new one.
6. Refer to Figure 7.3.4. to ensure the direction of the belt conforms to the spindle position on the machine.
7. Release the four M12 nuts holding the motor to allow the belt to support the weight of the motor.
8. Adjust the tensioning screw clockwise until pressure is applied to the motor mounting rim.
9. To tension belt: ( a ) Measure the distance from the motor rim to the bottom of the tension screw pad. ( b ) Turn tensioning screw clockwise to move the motor rim down a further 8mm.

**Please note do not overtighten the drive belts.**

10. Tighten the M10 locking nut.
11. Tighten the four M12 nuts to secure the motor in the new position.
12. Re-assemble all tin covers and replace all rear and front safety covers prior to production operations.

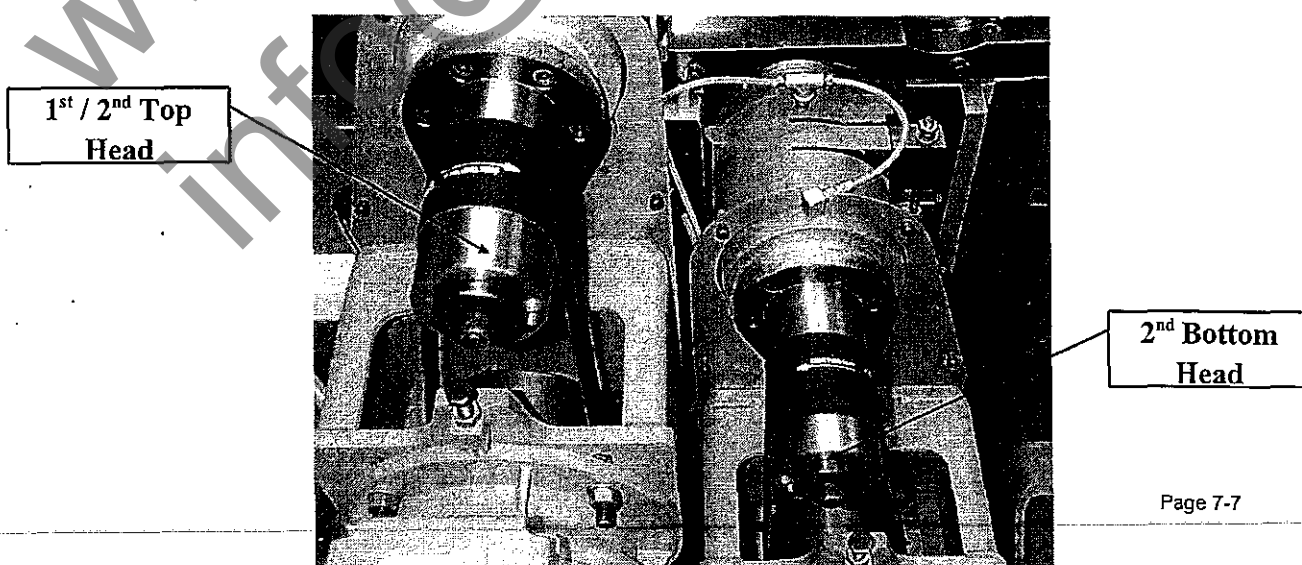

Figure 7.3.4

### 7.3.5 Replacing K23/K25 Fence and Near Side Head Drive Belts (Figure 7.3.5.)

**Please note that the shared drive belt for the vertical side heads is automatically tensioned by a gas spring.**

1. Remove all front and rear safety covers to enable access to all horizontal heads.
2. Remove all tin covers to allow access to the drive belt.
3. Place the supplied lever tool (Figure 7.3.5.) with the hole in the tool fitting over the idle belt roller pivot.
4. Applying force on the lever push the idle roller back against the gas spring pressure and remove the belt. **Please note** to remember to allow the gas spring to gently push the idle roller back after the belt is removed.
5. Check the drive belt for wear or cracking. Replace if necessary and replace with the **correct** new one.
6. Refer to Figure 7.3.5. to ensure the direction of the belt conforms to the spindle position on the machine.
7. When replacing the belt it should be firstly placed around the drive motor pulley ( 1 ) then the fence spindle and near side spindle and finally over the idle roller ( 2 ).
8. Turn the spindle to check the belt is running true and equal on the pulleys. The idle roller may need to be pitched by adjusting the pivot screw (refer to (4) figure 7.3.3) to achieve this.
9. Tighten the locking screw (refer to (5) figure 7.3.3) once the belt has been trued in relation to the motor pulley.
10. Re-assemble all tin covers and replace all rear and front safety covers prior to production operations.

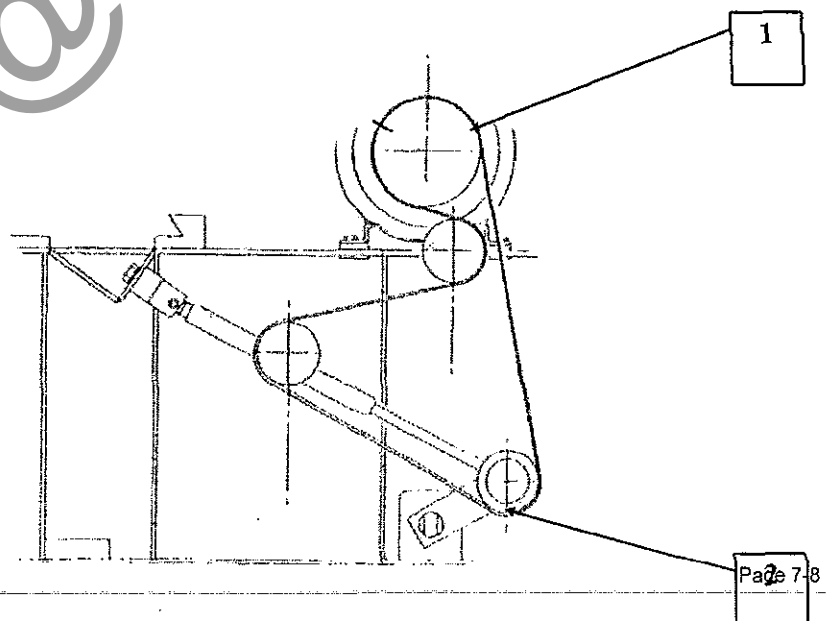

Figure 7.3.5

## 7.4 Fault Finding

### 7.4.1 General

Many of the faults occurring on woodworking machinery, apart from those caused by electrical or major mechanical failure, can be attributed to incorrect setting-up of the machine. Badly-tensioned drive belts, incorrectly set cutter blocks and loose components are frequent causes of irritating, often minor, faults.

When a fault occurs, unless the cause is because of a major mechanical or electrical failure or an operator error, it is recommended that the machine set-up is reviewed before any other investigative work is undertaken.

### 7.4.2 Workpiece Faults

Listed below are problems identified on the product after processing, with an indication of the diagnosis and remedy.

#### **FAULT - Blips at leading end of underside of product**

##### **Diagnosis/Remedy**

Cutter block set too low in relation to bedplate - Adjust cutter block.

#### **FAULT - Blips on trailing end of underside of product**

##### **Diagnosis/Remedy**

Cutter block set too high in relation to bedplate - Adjust cutter block.

#### **FAULT - Trailing end of product top face shows blips**

##### **Diagnosis/Remedy**

Pad and roller pressures are set incorrectly - Adjust pressures.

#### **FAULT - Out of square product**

##### **Diagnosis/Remedy**

Cutter block cutters not set parallel to bedplate or badly ground - Inspect/adjust cutter block.

#### **FAULT - Burn marks on product**

##### **Diagnosis/Remedy**

Cutter block cutters blunt - Inspect/regrind.  
Timber stationary in machine - Remove timber.

### 7.4.3 Machine Faults

Detailed below is a number of fault conditions with associated diagnoses and the recommended remedial action. The diagnoses should be considered only advisory; a proper determination of any fault is more likely to be ascertained by the competent engineer called to rectify the problem.

Note that obvious operator errors (switches not closed, enclosure open, etc.) are not listed in the diagnoses below.

**FAULT- None of the spindle drives nor the feed drive operates when the Start buttons are pressed**

**Diagnosis/Remedy**

Circuit breaker out - Reset circuit breaker.

Main fuse or control fuse blown - Check fuses and replace.

If either fault re-occurs, investigate for cause on the machine.

**FAULT - A spindle motor or feed motor does not start**

**Diagnosis/Remedy**

Circuit breaker out - Reset circuit breaker.

Motor fuse blown - Check fuse and replace.

Motor contactor failed - Check contactor for pitted contacts or mechanical failure.

Open circuit in motor line leads - Check circuit and correct.

If fuse or circuit breaker fault re-occurs, investigate for cause on the motor.

**FAULT - Motor contactor makes noise on closing**

**Diagnosis/Remedy**

Supply voltage too low - Check supply voltage with meter.

Contactors contacts pitted or dirty - Clean or replace contacts.

**FAULT - After a motor has started, circuit breaker trips or a motor fuse blows**

**Diagnosis/Remedy**

Motor/spindle seized on bearings - Check and replace.

Failure in circuit to motor (line lead earthed or short circuit) - Check with resistance and continuity meter.

**FAULT - Motor overheats while running unloaded**

**Diagnosis/Remedy**

Supply voltage too high - Check supply voltage with meter.

Motor windings incorrectly connected - Check for correct starting/running connections.

Motor air ducts blocked impeding flow of cooling air - Clear ducts.

**FAULT - Motor overheats while running loaded**

**Diagnosis/Remedy**

Establish if mechanical problem - Check spindle for seizure/incorrect setting.

Single phase operation in motor line leads - Check circuit and correct.

**FAULT - Motor noisy when running**

**Diagnosis/Remedy**

Establish if mechanical or electrical problem - If mechanical, noise will change in intensity/frequency with change in motor speed; if electrical, noise will continue after motor has stopped. Carry out appropriate investigation.

**FAULT - Spindle stops while motor is still running**

**Diagnosis/Remedy**

Slipping or broken belt - Check and retighten or replace.

**FAULT - Motor contactor remains closed after operation of Stop button**

**Diagnosis/Remedy**

Contactors contacts have 'welded' together - Replace contacts.



## 7.5 Lubrication Chart

### 7.5.1 Lubricants specified

Hydraulic oil with anti-corrosion, anti-oxidation and anti-foam qualities.

Grease - Lithium mineral bearing grease with NLG1 No.3 consistency.

### 7.5.2 Approved Lubricants

Hydraulic Oil	Grease
Castrol Hyspin AWS32	Castrol Spheerol AP3
BP Energol HLP32	Energrease LS3
Shell Tellus 32	Shell Alvania grease R3
Mobil DTE light 24	Mobilplex 48
Esso Nuto 44/ESSTIC H44	Esso Beacon 3
Gulf Harmony 32AW	Gulf Crown No.3
Elf Elfona 32	Elf Multi 3 grease
Kluber Lamora HLP 32	Kluber Centoplex 3

## 7.6 Tool and Toolholder Care

When selecting tools, care must be taken to ensure that they are suitable for 6000rev/min operation (dynamically and statically balanced and checked for damage).

The life of the tool depends upon the quality of the cutter steel, quality of knife grinding, and the type of wood being machined.

When sharpening, care should be taken to ensure that the blade is not unduly heated by using the correct type of grinding wheel, coolant, chip removal process, etc.

Moreover, with multi-toothed tools, the correct tooth pitch is important to ensure effective cutting.

Whether a tool is effective depends much on how it is used. Careful handling will ensure longer service life and improved product quality.

Tooling should comply with the Tooling Standard PREN 847-1: 1997.

www.wadkin.com  
info@wadkin.com

## 8 ADDITIONAL EQUIPMENT

---

### 8.1 General

This Section covers the additional equipment which can be added to the Model K23/K25 but which does not form part of the basic machine described in the previous Sections of this Operation and Maintenance Manual.

Each Section gives a brief description of the equipment features, its purpose and any setting-up procedures necessary to integrate it into the machine operation.

All preparation and safety procedures detailed in the setting-up procedures given in Section 6 must also be complied with when carrying out the procedures given in this Section.

### 8.2 Meterage counter

The K23/K25 may be specified with a meterage counter as an option. This option is an electro-mechanical unit and gives the following information:-

- Total meterage run through the machine.
- Screen to set meterage for one job.
- Total of meterage for one job run.

During machine operation the feed will run until the meterage set in the 'set screen' has been reached. When this happens the feed will stop. The feed will not run again until it has been reset to a new value.

A small tool is supplied which will 'zero' the top screen which allows the m/c to run for the next setting.

To reset the meterage for one run, hold down the white button and press each of the other buttons until screen reads required meterage. The m/c will now run until the new meterage figure has been run through the m/c.

Total M/C Meterage

Total Meterage For One job

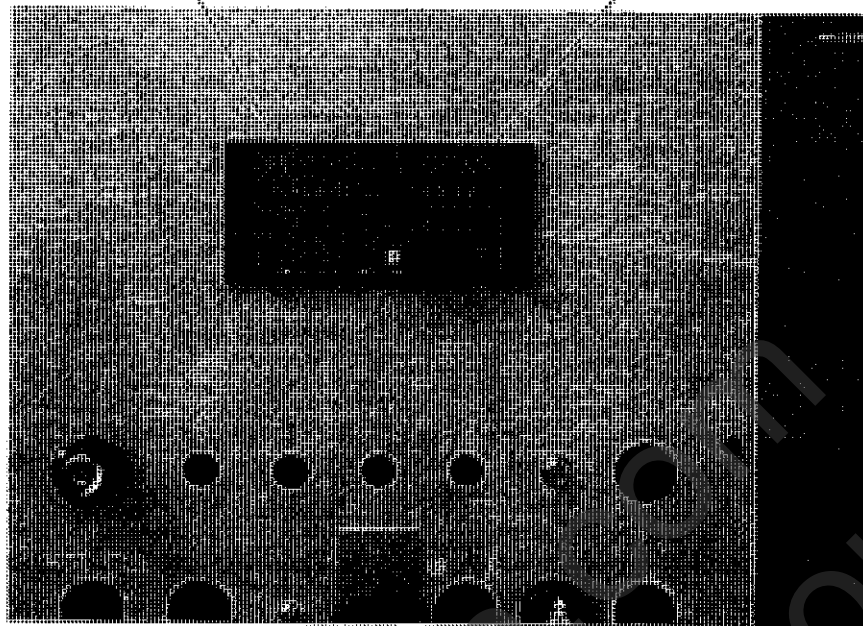

Setting Screen For One Job

Figure 1 : Meterage Control Panel

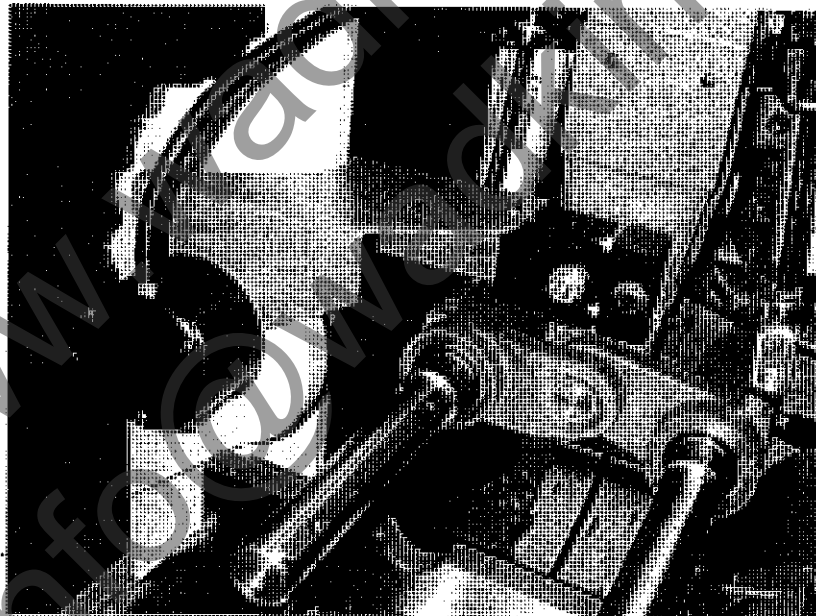

Bottom Stop Screw

Meterage counter Wheel

Figure 2 : Meterage Counter Unit

A bottom stop is provided to set the counter roller in line with the poly feedrollers. This will be factory set.

### 8.3 Short Infeed Table Including Pneumatically Linked Driven Infeed Rollers.

The short infeed table is fitted to the K23/K25 as an option when straightening is not required by the customer. Typical applications for the short infeed table are:- strip mouldings, skirting boards and architraves.

#### 8.3.1 Pneumatically linked driven infeed roller. (fig 1)

The short infeed table option comes complete with the linked infeed driven roller system, unique to Wadkin. The main control panel has a separate air regulator and gauge to allow individual adjustment. The top roller has a separate adjuster to control its height. Also shown are the side pressure roller, (standard for the short infeed option) and the splinter catching device (optional), which is specified when splitting is required by the customer.

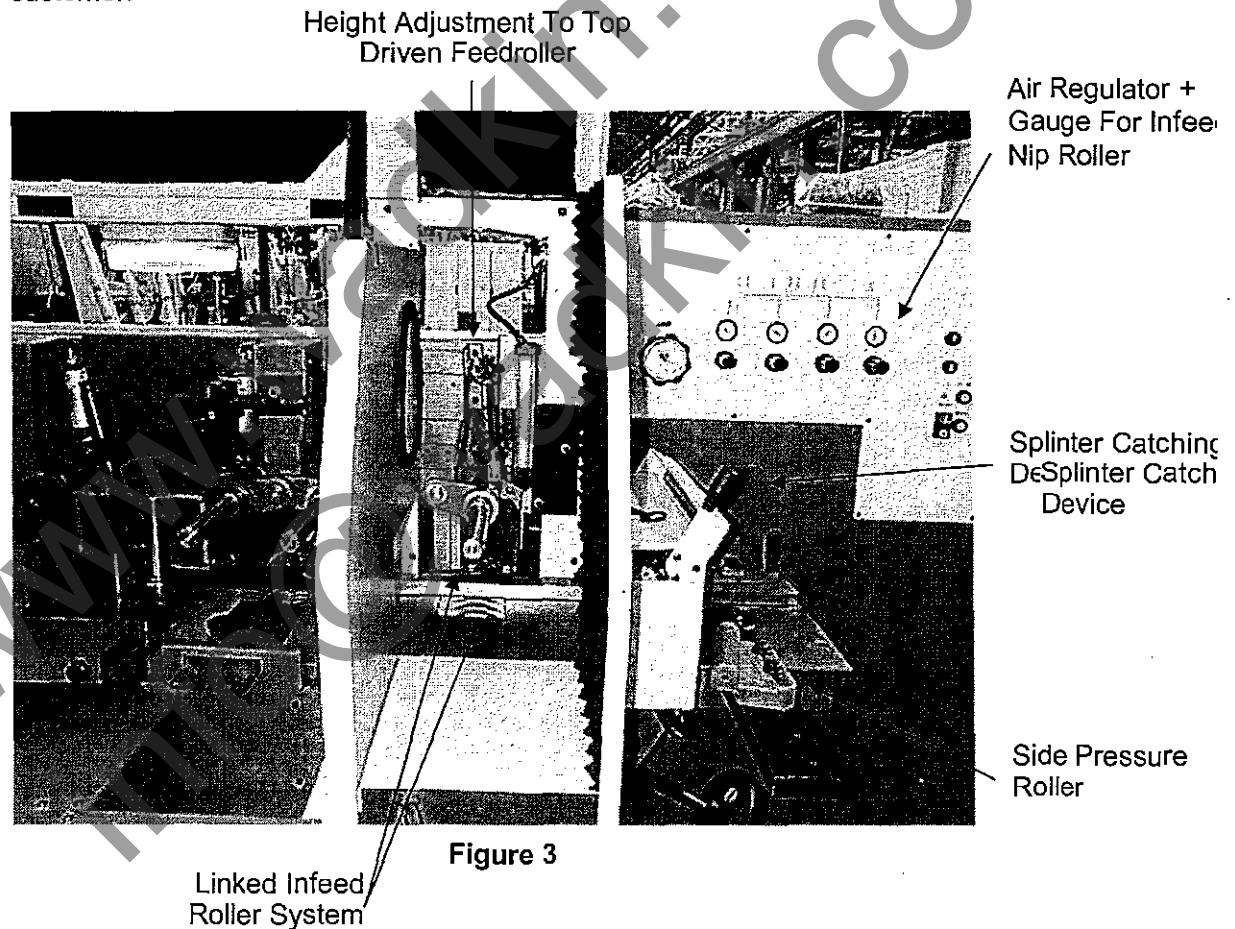

### 8.3.2 Infeed table height adjustment. (fig 4)

The large hand wheel shown raises and lowers the infeed table. Adjustment is 0 – 10 mm and a scale is provided. When setting, the final movement should be made in the direction of the bed.

Also shown in fig 4 are the separate bed and slide oil lubrication tanks.

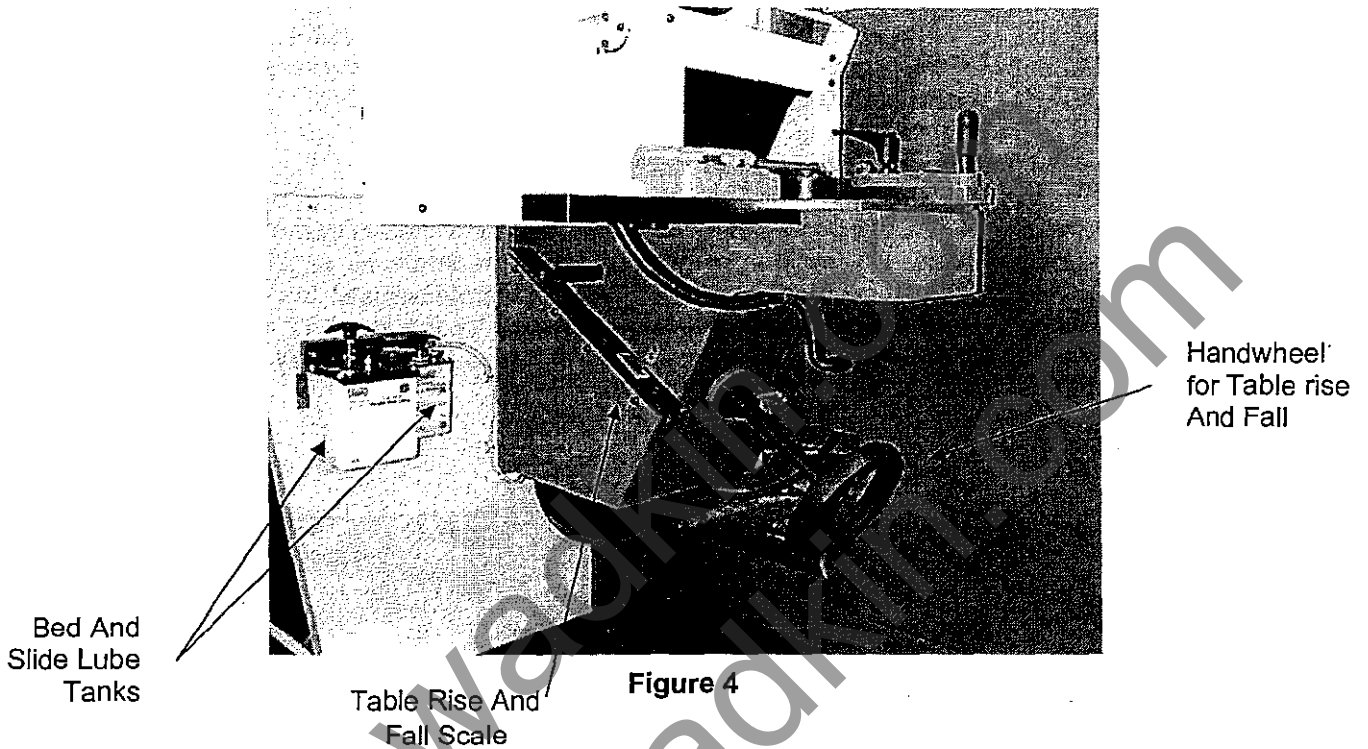

### 8.3.3 Height adjustment of driven bed roller. (fig 5)

The positions for the rollers will be factory set, however it may sometimes be necessary to alter these positions due to special working conditions.

Adjustment of the driven bed roller is controlled by two locks situated on the front face of the table.

1. Both locks are a combined stop and lock.
  2. Using a 24mm spanner unlock the long hexagon shaft.
  3. Using a 13mm spanner adjust the roller until it is in the required position.
  4. Lock up the long hexagon shaft.
- (This is repeated for the top position)



## 8.4 Splitting Bedplate (Figure 8.4.1)

This enables timber passing through the machine to be split into predetermined widths as set by the positions of the blades on the rotating spindle.

The splitting bedplate consists of a Permali splitting bedplate, two sections of splitting bedplate and a Permali pad pressure plate. Particular attention should be drawn to the process of dividing the workpiece ie by saw units or multi-profiling units. Under such operation a Catching Finger Device (sometimes known as an Anti Kickback unit), **MUST BE FITTED** to prevent ejection of divided parts and splinters of the workpiece.

### 8.4.1 Fitting

- 1 Slacken nuts and remove clamps (1); remove bedplates.
- 2 Remove the pad pressure plate from the first top head (refer to Section ?).
- 3 Fit the rotating saw and spacers (see Section 5); set the first blade to the required distance from the fence to give the width of timber. Set the other spacers as necessary.

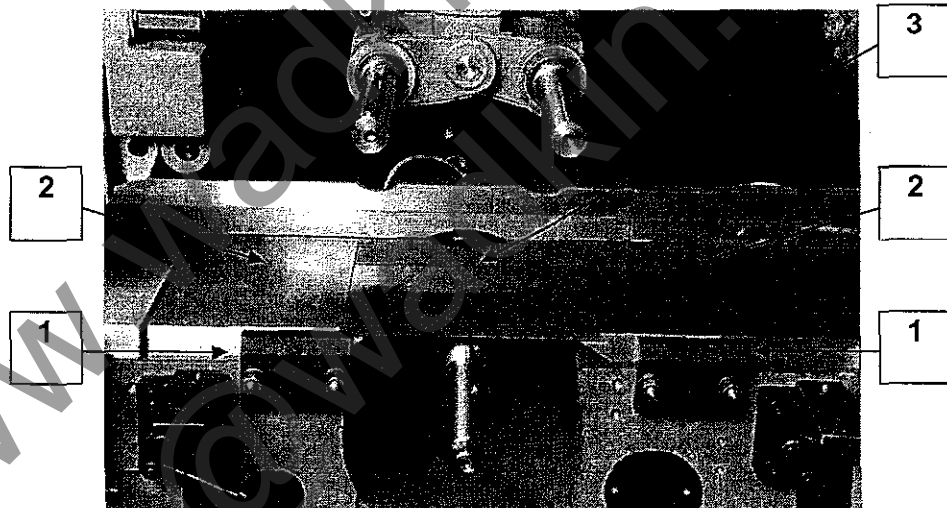

Figure 8.4.1

- 4 Fit the Permali pad pressure plate to first top head.
- 5 Fit the two splitting bedplates (2) and hold in position with the clamps (1) with the nuts only finger tight.
- 6 Fit the Permali splitting bedplate (3) between the two splitting bedplates, sliding the rear edge beneath the fence of the machine.
- 7 Centralise all three bedplates ensuring that dovetails are correctly located, and tighten nuts.



- 8 Ensure that saw blades are positioned correctly to align with slots in the Permali splitting bedplate (if already pre-cut).  
  
If a new Permali bedplate is being used, position saws beneath the bedplate and cut slots in the bedplate with the saws.
- 9 Adjust the height of the saw blades to provide the required cut to suit the timber thickness.
- 10 The splitting bedplate is now set-up.

[www.wadkin.com](http://www.wadkin.com)  
[info@wadkin.com](mailto:info@wadkin.com)

## 8.5 99 Setting Programmable Memory Positioning

### Near Side Head and Top Head.

This unit has the capacity to be programmable for ninety-nine positional head settings.

The powered traverse movement to the near side head is by a geared motor.

The traverse movements of the heads are each connected to an 'encoder' which sends pulse signals to a digital read out controller, (see fig. 8.5.1,) situated on the electrical control panel.

The traverse of the heads reacts to input data into the controller, which displays the cutter block position in relation to its datum face. The datum face for the near side head is the fence and the datum for the top head is the bedplate.

The head traverse movements may be hand or power operated, a switch is provided for this purpose which can also be found on the control panel.

Refer to 'Elgo Electric' Programmable Position Control Manual for operating instructions.

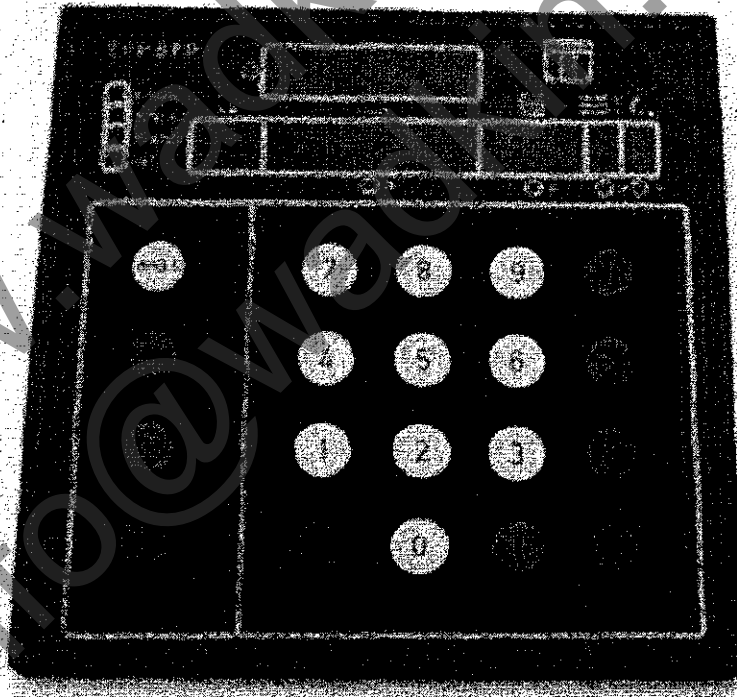

Figure 8.5.1



## GLOSSARY

---

Below is a Glossary of terms used in this manual specific to the equipment being described. Other documents which should be referred to are listed in Section 1.1.6.

Bed	Machine surface on which timber travels through the machine.
Blips	Marks on planed timber indicating fault in processing.
Chipbreaker	Device which provides pressure to hold the timber on to the machine bed, or against fence, depending on position.
Cutter head	A rotating cutting tool, for working various surfaces on wood and similar materials through chip removal.
Datum block	Block of material of known height/width used as tool to datum machine settings.
dB	Decibel of noise (measurement of noise level).
Drive belt	Flat, 'V' or toothed belt which drives the spindles from the motor drive shaft.
Feed rolls	Rotating rolls which traverse the material through the machine also exerting the necessary pressure to ensure proper control
Feed speed	Speed at which material is passed through the machine. The speed is dictated by the surface quality required on the product.
Fence side head	Vertical spindle positioned on the right-hand side of the material (when viewed from the infeed end of the machine).
First bottom head	First horizontal spindle positioned below the bed.
First top head	First horizontal spindle positioned above the bed.
Infeed	End of machine where timber is introduced.

Near side head	Vertical spindle positioned on the left-hand side of the material (when viewed from the infeed end of the machine).
Outfeed	End of machine where finished product is produced.
Spindle	Rotating shaft carrying the cutter block.
Test piece	Timber on which setting-up processes are conducted.

[www.wadkin.com](http://www.wadkin.com)  
[info@wadkin.com](mailto:info@wadkin.com)



**ULTRACARE**

*At the Cutting Edge of Industry*

**K23/K25**

**THROUGH FEED FOUR  
SIDE PLANING  
MACHINE**

**ILLUSTRATED PARTS LIST**

**PARTS MANUAL No.2035/1**

ILLUSTRATED PARTS LIST – MODEL K23  
WADKIN LIMITED, LEICESTER

## CONTENTS

PAGE NO.	DESCRIPTION
1	FENCES, BEDPLATES & SIDE GUIDES (LONG INFEED)
2	FENCES, BEDPLATES & SIDE GUIDES (SHORT INFEED)
3	SHORT INFEED TABLE
4	SIDE ROLLER PRESSURE UNIT
5	ANTI-KICKBACK UNIT
6	SPINDLE UNIT
7	FIRST BOTTOM HEAD
8	TOP IDLE ROLLER PRESSURE
9	BELT ARRANGEMENT (NEAR SIDE HEAD/FENCE SIDE HEAD SPINDLE)
10	FENCE SIDE HEAD CARRIAGE
11	NEAR SIDE HEAD CARRIAGE
12	FENCE SIDE HEAD & NEAR SIDE HEAD LATERAL ADJUSTMENT GEARBOX
13	SIDE HEAD LOCKING ARRANGEMENT
14	TOP HEAD ADJUSTMENT
15	TOP HEAD RISE & FALL BEVEL BOX – SHEET 1

**NOTE: WHEN ORDERING PARTS, PLEASE QUOTE MACHINE MODEL AND SERIAL NUMBER.**

ILLUSTRATED PARTS LIST – MODEL K23  
WADKIN LIMITED, LEICESTER

## CONTENTS

PAGE NO.	DESCRIPTION
16	TOP HEAD RISE & FALL BEVEL BOX – SHEET 2
17	TOP HEAD RISE & FALL BEVEL BOX – SHEET 3
18	TOP/SECOND BOTTOM SPINDLE AXIAL ADJUSTMENT
19	TOP HEAD CHIPBREAKER
20	TOP HEAD PAD PRESSURE (SINGLE)
21	TOP HEAD PAD PRESSURE (SPLIT)
22	DRIVEN/IDLE BEDROLLER
23	SECOND BOTTOM HEAD ADJUSTMENT
24	BOTTOM HEAD RISE & FALL BEVEL BOX
25	SECOND BOTTOM HEAD BARREL LOCKING
26	BEAM AND GEARBOX ARRANGEMENTS
27	SIMPLABELT Z CONFIGURATION VARIABLE SPEED DRIVE
28	BEAM RISE & FALL BEVEL BOX
29	SHAFT MOUNTED FEEDROLL
30	FLANGED MOUNTED FEEDROLL



**K23 (LONG INFEED)**

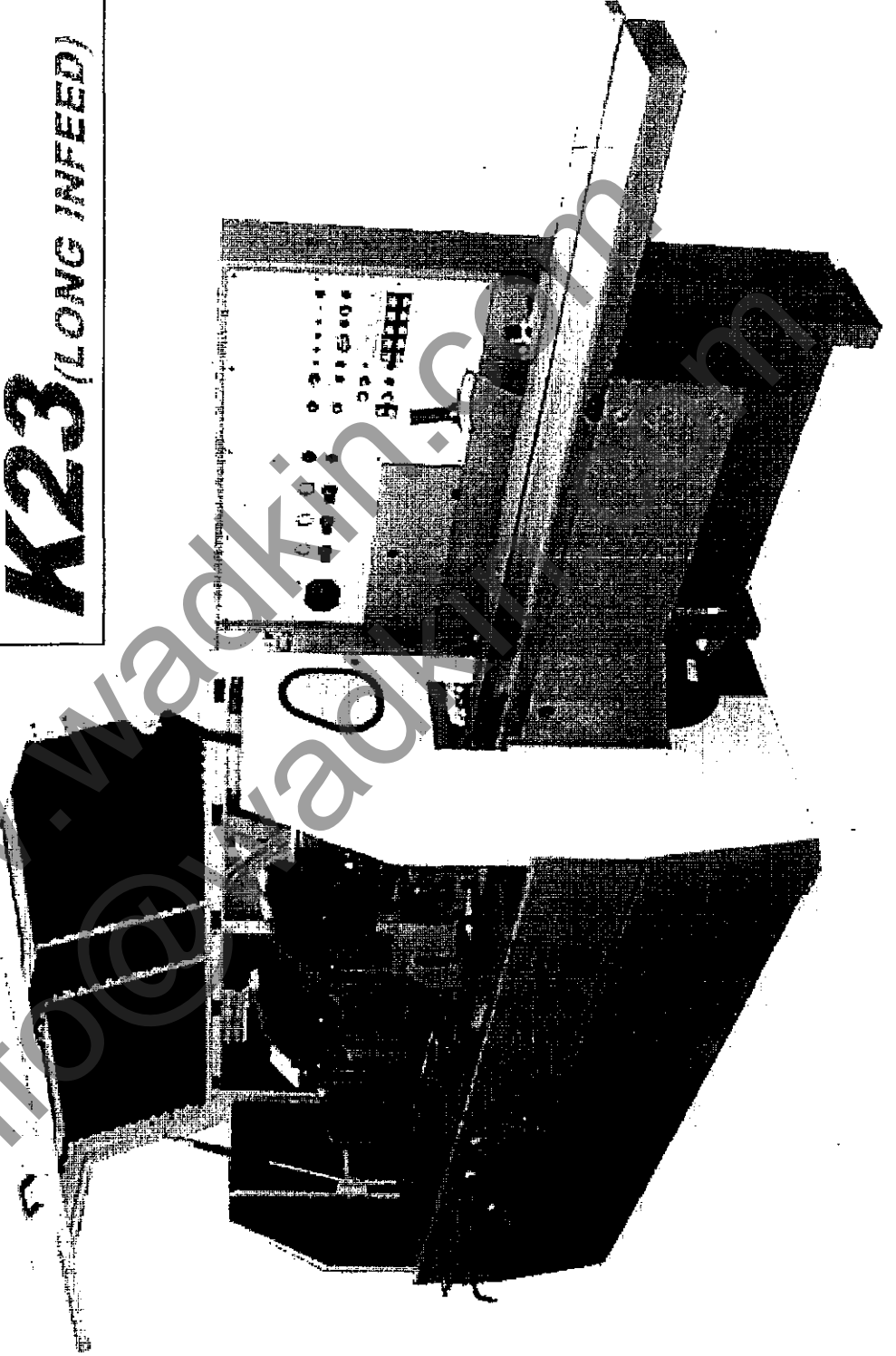

ILLUSTRATED PARTS LIST – MODEL K23  
WADKIN LIMITED, LEICESTER

DESCRIPTION: FENCES, BEDPLATES & SIDE GUIDES (LONG INFEED)

REF. NO.	PART DESCRIPTION	QUANTITY
1	BEDPLATE AFTER SECOND BOTTOM HEAD	1
2	FENCE OVER SECOND BOTTOM HEAD	1
3	FENCE SUPPORT, OUTFEED	1
4	BEDPLATE BEFORE SECOND BOTTOM HEAD	1
5	FENCE SUPPORT BETWEEN TOP HEADS	1
6	BEDPLATE UNDER TOP HEADS	2
7	FENCE BETWEEN TOP HEADS	1
8	FENCE BEFORE FIRST TOP HEAD	1
9	FENCE SUPPORT – FENCE SIDE HEAD TO FIRST TOP HEAD	1
10	FENCE NOSEPIECE AFTER FENCE SIDE HEAD	1
11	FENCE NOSEPIECE REBATING	1
12	SERRATED CLAMP PLATE	1
13	LIP PLATE FOR INFEED TABLE	1
14	BEDPLATE AFTER FIRST BOTTOM HEAD	1
15	FENCE SIDE HEAD BEDPLATE	1
16	BEDPLATE BETWEEN FENCE SIDE HEAD AND NEAR SIDE HEAD	1
17	NEAR SIDE HEAD BEDPLATE	1
18	SIDE GUIDE UNDER TOP HEADS	1
19	FRONT FENCE SUPPORT BRACKET	4
20	VERTICAL SHAFT FOR SUPPORT	4
21	SIDE GUIDE AFTER SECOND BOTTOM HEAD	1

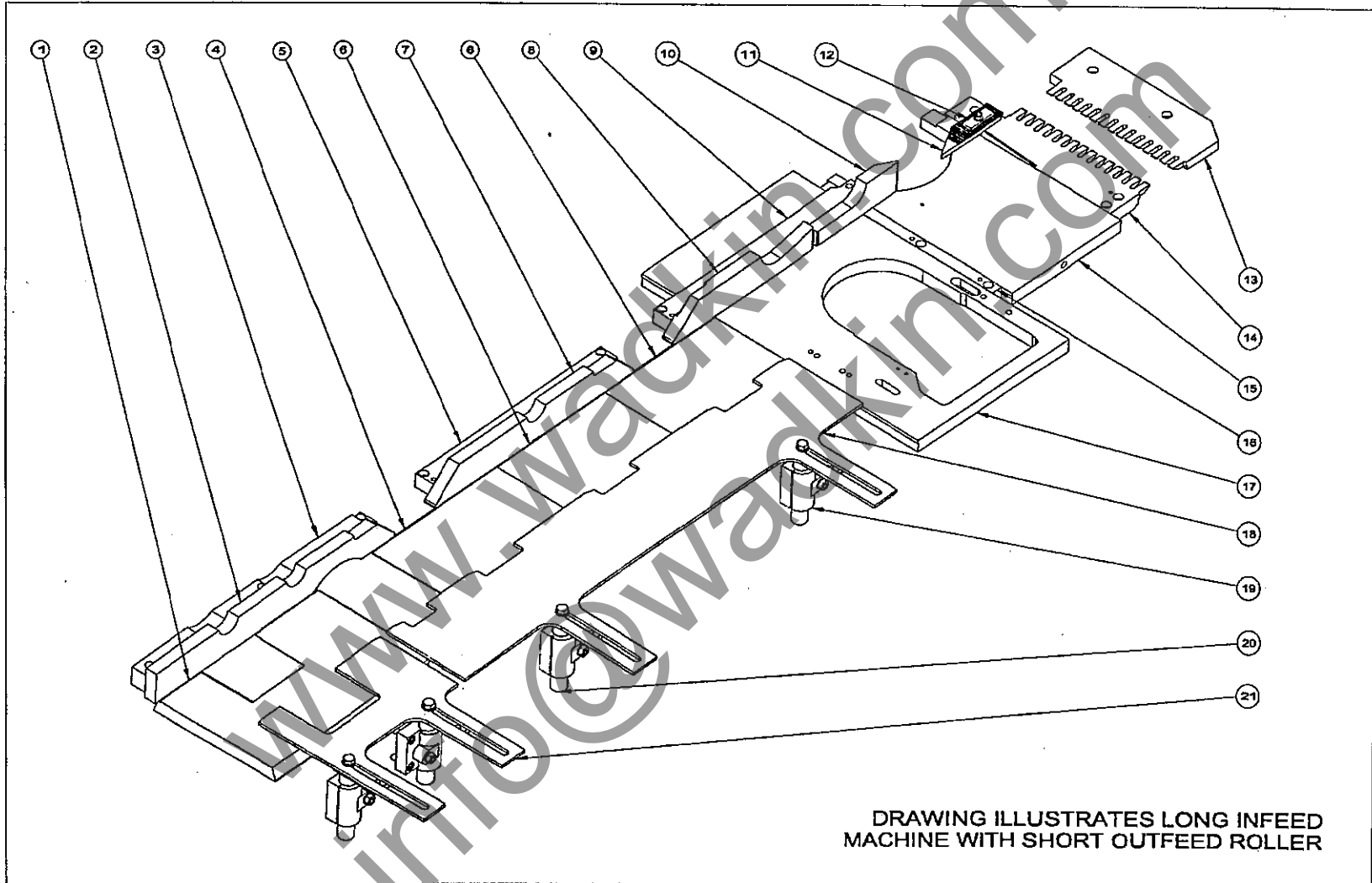

DRAWING ILLUSTRATES LONG INFEED MACHINE WITH SHORT OUTFEED ROLLER

WADKIN LIMITED. LEICESTER

ASSEMBLY PROFILE OF  
FENCES, BEDPLATES & SIDE GUIDES

DRAWN BY: S.J.DAVIS

ILLUSTRATED PARTS LIST – MODEL K23  
WADKIN LIMITED, LEICESTER

DESCRIPTION: FENCES, BEDPLATES & SIDE GUIDES (SHORT INFEED)

REF. NO.	PART DESCRIPTION	QUANTITY
1	BEDPLATE AFTER INTERMEDIATE AND OUTFEED ROLLER	2
2	FENCE OVER SECOND BOTTOM HEAD	1
3	SHORT BEDPLATE AFTER SECOND BOTTOM HEAD	1
4	FENCE SUPPORT, OUTFEED	1
5	BEDPLATE BEFORE SECOND BOTTOM HEAD – INTERMEDIATE BEDROLL	1
6	FENCE SUPPORT BETWEEN TOP HEADS	1
7	FENCE BETWEEN TOP HEADS	1
8	BEDPLATE BEFORE INTERMEDIATE BEDROLL	1
9	BEDPLATE UNDER TOP HEADS	1
10	FENCE BEFORE FIRST TOP HEAD	1
11	FENCE SUPPORT – FENCE SIDE HEAD TO FIRST TOP HEAD	1
12	FENCE NOSEPIECE AFTER FENCE SIDE HEAD	1
13	LIP PLATE FOR INFEED TABLE	1
14	BEDPLATE AFTER FIRST BOTTOM HEAD – SHORT INFEED	1
15	FENCE SIDE HEAD BEDPLATE	1
16	BEDPLATE BETWEEN FENCE SIDE HEAD AND NEAR SIDE HEAD	1
17	NEAR SIDE HEAD BEDPLATE	1
18	SIDE GUIDE UNDER TOP HEADS	1
19	FRONT FENCE SUPPORT BRACKET	4
20	VERTICAL SHAFT FOR SUPPORT	4
21	SIDE GUIDE AFTER SECOND BOTTOM HEAD	1

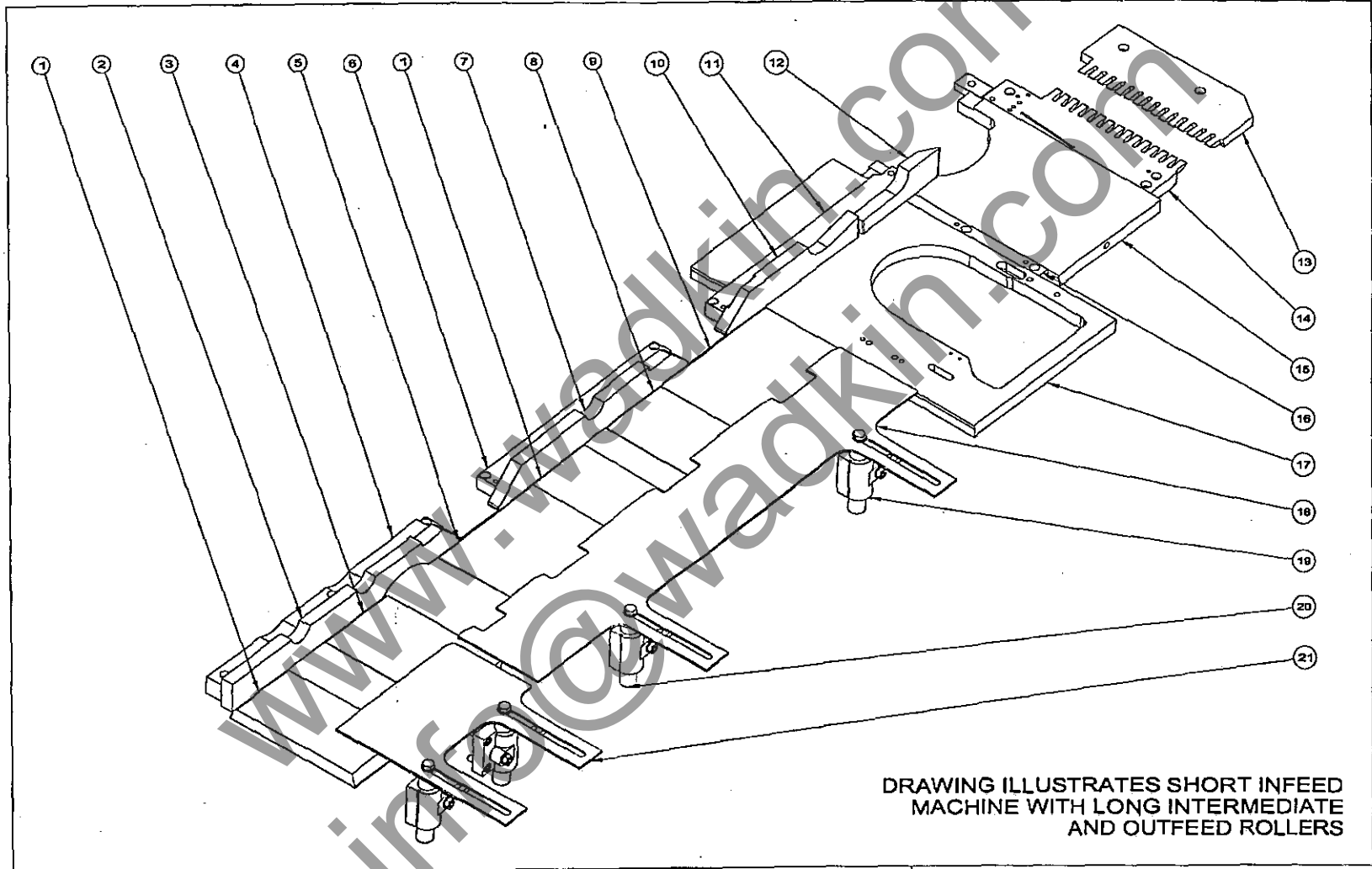

WADKIN LIMITED. LEICESTER	ASSEMBLY PROFILE OF FENCES, BEDPLATES & SIDE GUIDES	DRAWN BY: S.J.DAVIS
---------------------------	--------------------------------------------------------	---------------------

ILLUSTRATED PARTS LIST – MODEL K23  
WADKIN LIMITED, LEICESTER

DESCRIPTION: SHORT INFEEED TABLE

REF. NO.	PART DESCRIPTION	QUANTITY
1	TOP DRIVEN INFEEED SHAFT FOR ROLLERS	1
2	BOTTOM DRIVEN INFEEED ROLLERS	3
3	SHORT INFEEED CRADLE	1
4	TOP POSITION ROLLER HEIGHT ADJUSTMENT CONTROL	1
5	BOTTOM POSITION ROLLER HEIGHT ADJUSTMENT CONTROL	1
6	FRONT LIP PLATE (REAR NOT SHOWN)	1
7	PNEUMATIC CYLINDER FOR PURE HORIZONTAL THRUST	1
8	INFEEED FENCE FOR SHORT INFEEED	1
9	INFEEED FENCE ADJUSTMENT CONTROL PLATE	1
10	BEDPLATE FOR SHORT INFEEED TABLE	1
11	SHORT INFEEED TABLE	1
12	TABLE RISE AND FALL ADJUSTING SCREW	1
13	ADDITIONAL LIFT UP COVER FOR SHORT INFEEED	1
14	ELECTRICAL CABINET (SHORT & LONG INFEEED MACHINE)	1
15	FOOT AND ELECTRICAL CABINET SUPPORT FOR SHORT INFEEED	1

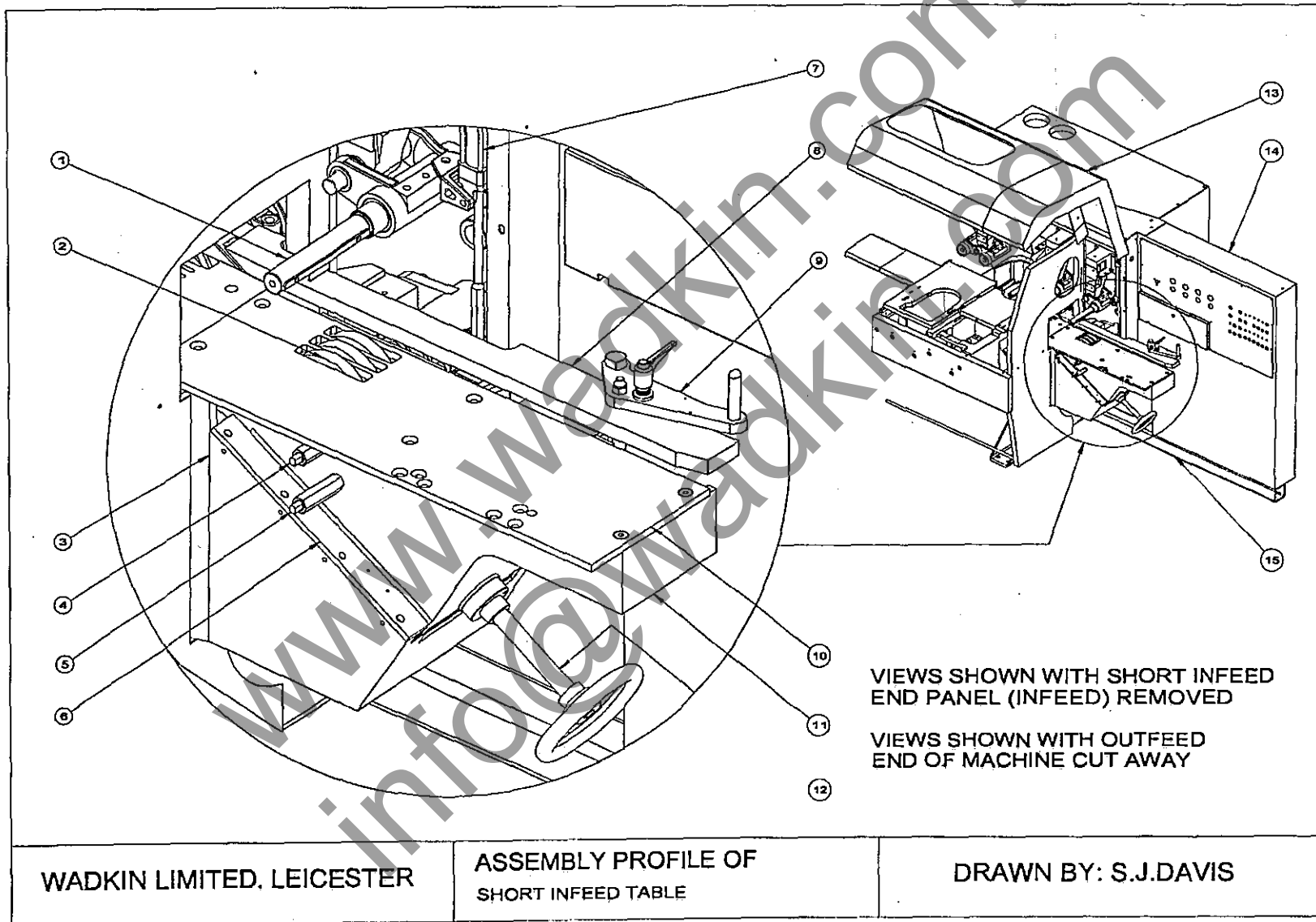

ILLUSTRATED PARTS LIST – MODEL K23  
WADKIN LIMITED, LEICESTER

DESCRIPTION: SIDE ROLLER PRESSURE UNIT

REF. NO.	PART DESCRIPTION	QUANTITY
1	M12 X 60mm HEXAGON HEAD SCREW	2
2	CLAMPING WASHER	2
3	SINGLE ROLLER SIDE PRESSURE BRACKET	1
4	SPRING	1
5	8mm DIAMETER X 30mm LONG TENSION PIN	1
6	5mm DIAMETER X 30mm LONG TENSION PIN	1
7	SUPPORT PLATE FOR SIDE ROLLER PRESSURE	1
8	PRESSURE ROLLER SLIDING SHAFT	1
9	ROLLER PIN FOR SIDE PRESSURE	1
10	ROLLER FOR SIDE PRESSURE	1
11	6004-2RS RHP & SKF BEARING	1
12	20mm DIAMETER EXTERNAL CIRCLIP	1



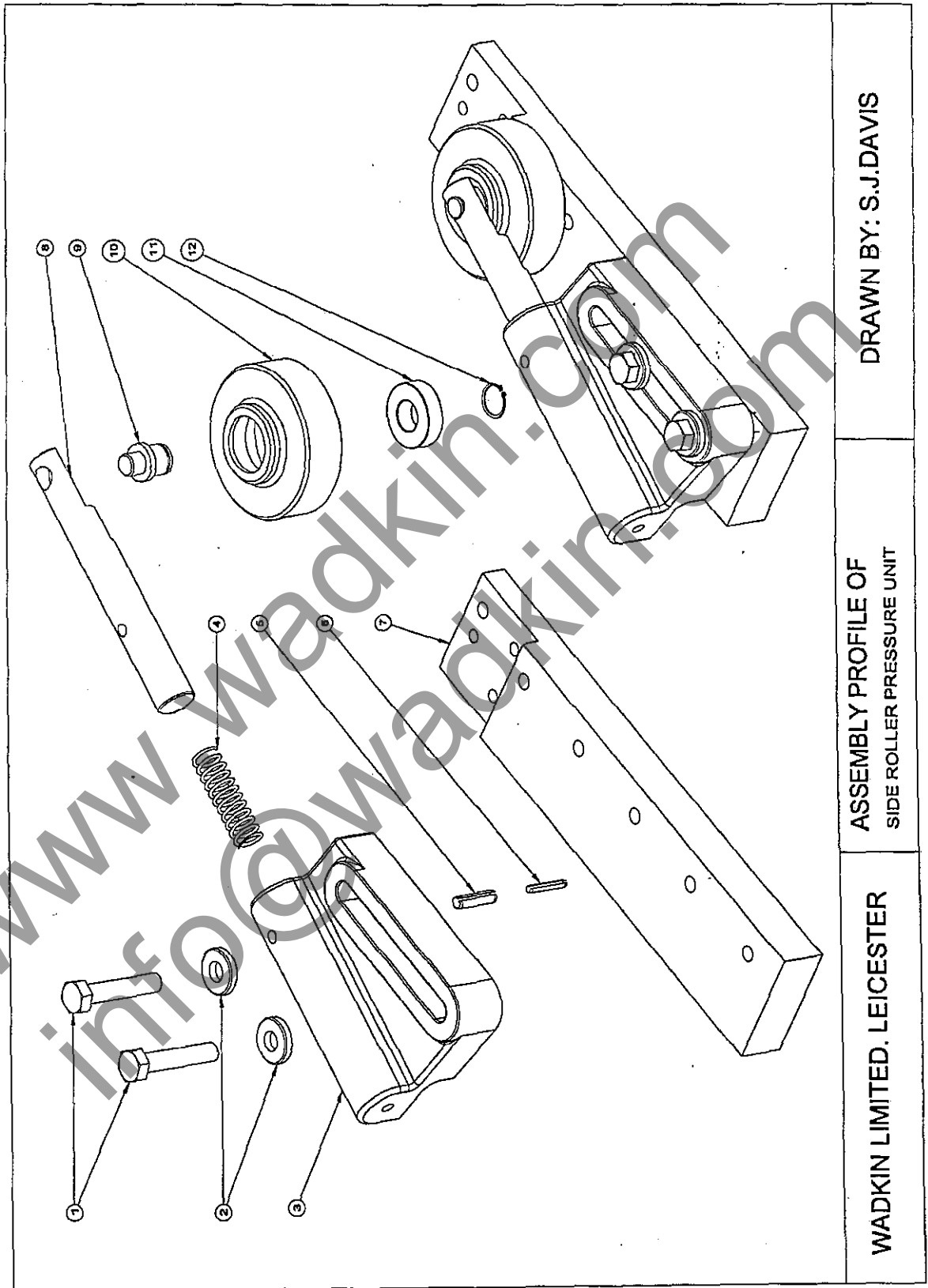

DRAWN BY: S.J.DAVIS

ASSEMBLY PROFILE OF  
SIDE ROLLER PRESSURE UNIT

WADKIN LIMITED. LEICESTER

ILLUSTRATED PARTS LIST – MODEL K23  
WADKIN LIMITED, LEICESTER

DESCRIPTION: ANTI-KICKBACK UNIT

REF. NO.	PART DESCRIPTION	QUANTITY
1	SHORT INFEED BEDPLATE	1
2	ANTI-KICKBACK FINGER	26
3	AS-2035 INA THRUST WASHER	27
4	20mm ID X 28mm OD X 10mm LONG BUSH	26
5	BLOCK FOR FINGER LIFT	2
6	STANDARD TAPER PIN NO. 2	2
7	SHAFT FOR ANTI-KICKBACK FINGERS	1
8	BLOCK FOR ANTI-KICKBACK SHAFT	1
9	20mm ID X 25mm OD X 15mm LONG BUSH	1
10	HANDLE FOR ANTI-KICKBACK FINGERS	1
11	PLATE TO LOFT ANTI-KICKBACK FINGERS	1
12	MOUNTING BRACKET FOR ANTI-KICKBACK UNIT LIMIT SWITCH	1
13	CAM FOR ANTI-KICKBACK UNIT	1
14	STANDARD TAPER PIN NO. 4	1
15	MOUNTING PLATE FOR ANTI-KICKBACK UNIT	1
16	MOUNTING BLOCK FOR ANTI-KICKBACK UNIT	1
17	20mm ID X 25mm OD X 20mm LONG BUSH	1
18	PLUNGER FOR ANTI-KICKBACK UNIT	1
19	STANDARD SPRING NO. 2	1
20	1.301/80 +X- M8 REVOLVING HANDLE	1

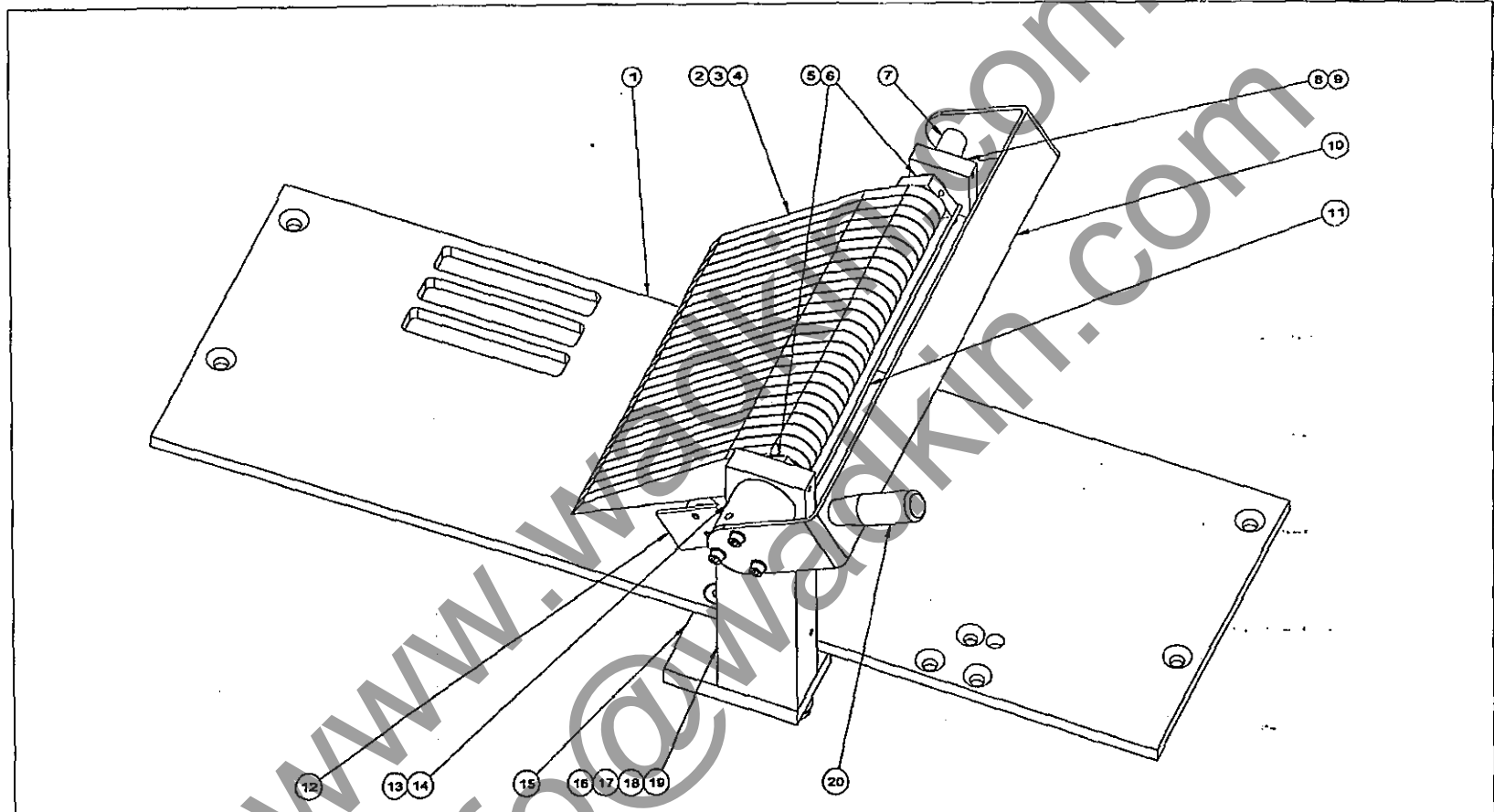

VIEW SHOWN WITH SHORT INFEEED BEDPLATE  
MOUNTING POSITION IDENTICAL FOR LONG INFEEED

ADDITIONAL ITEM - NOT ILLUSTRATED:  
COVER FOR ANTI-KICKBACK UNIT  
FENCE LOCKING EXTENSION - LONG INFEEED ONLY

WADKIN LIMITED. LEICESTER	ASSEMBLY PROFILE OF ANTI-KICKBACK UNIT	DRAWN BY: S.J.DAVIS
---------------------------	-------------------------------------------	---------------------

ILLUSTRATED PARTS LIST - MODEL K23  
WADKIN LIMITED, LEICESTER

DESCRIPTION: SPINDLE UNIT

REF. NO.	PART DESCRIPTION	QUANTITY
1	M8 X 20mm HEXAGON SOCKET CAPSCREW	6
2	HORIZONTAL BARREL END CAP	1
3	M12 X 40mm HEXAGON HEAD CAPSCREW	1
4	PULLEY RETAINING WASHER	1
5	SPINDLE PULLEY	1
6	FK6.ASD PISTON RING 75.0-79.5	1
7	RHP 7009 CTDUF-P4 PAIRED BEARING	1
8	40mm HORIZONTAL SPINDLE	1
9	SPINDLE BARREL	1
10	RHP 7012 CTDUL-P4 PAIRED BEARING	1
11	BEARING SPACER RING ASSEMBLY	1
12	OUTER THREADED LOCKNUT	1
13	FK6.ASD PISTON RING 70.0-74.5	1
14	INNER THREADED LOCKNUT	1
15	SPINDLE LOCKING COLLAR	1
16	SPINDLE SHAFT NUT	1
17	12mm X 8mm X 70mm LONG KEY	1
18	ADJUSTING NUT LEFT HANDED TRAPEZOIDAL	1
19	M6 X 25mm HEXAGON SOCKET CAPSCREW	3
<p>FOR USE ON FIRST BOTTOM HEAD SPINDLE ITEM 9 (BARREL) IS ECCENTRIC ALL OTHER SPINDLES USE A STANDARD CONCENTRIC BARREL</p>		

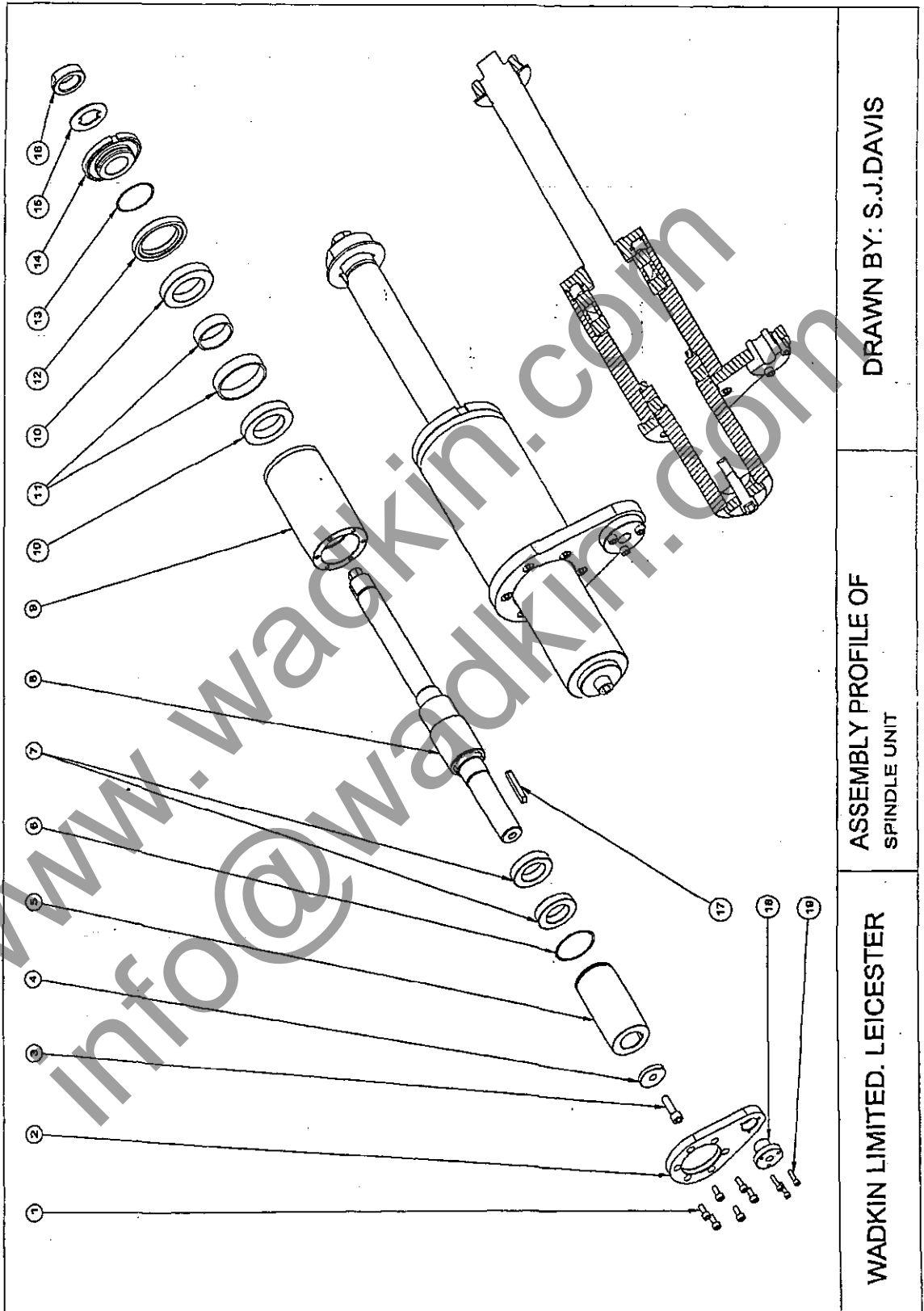

ILLUSTRATED PARTS LIST – MODEL K23  
WADKIN LIMITED, LEICESTER

DESCRIPTION: FIRST BOTTOM HEAD

REF. NO.	PART DESCRIPTION	QUANTITY
1	FIRST BOTTOM HEAD SPINDLE	1
2	FIRST BOTTOM HEAD MOUNTING	1
3	ECCENTRIC PIN FOR FIRST BOTTOM HEAD ADJUSTMENT	1
4	BACKPLATE FOR FIRST BOTTOM HEAD BELT COVER	1
5	FIRST BOTTOM HEAD DRIVE BELT	1
6	FIRST BOTTOM HEAD MOTOR	1
7	WORM FOR FIRST BOTTOM HEAD ADJUSTMENT	1
8	CLAMPING NUT	1
9	M12 TAPER WASHER 5 DEGREES	4
10	FIRST BOTTOM HEAD MOTOR MOUNTING BRACKET	1

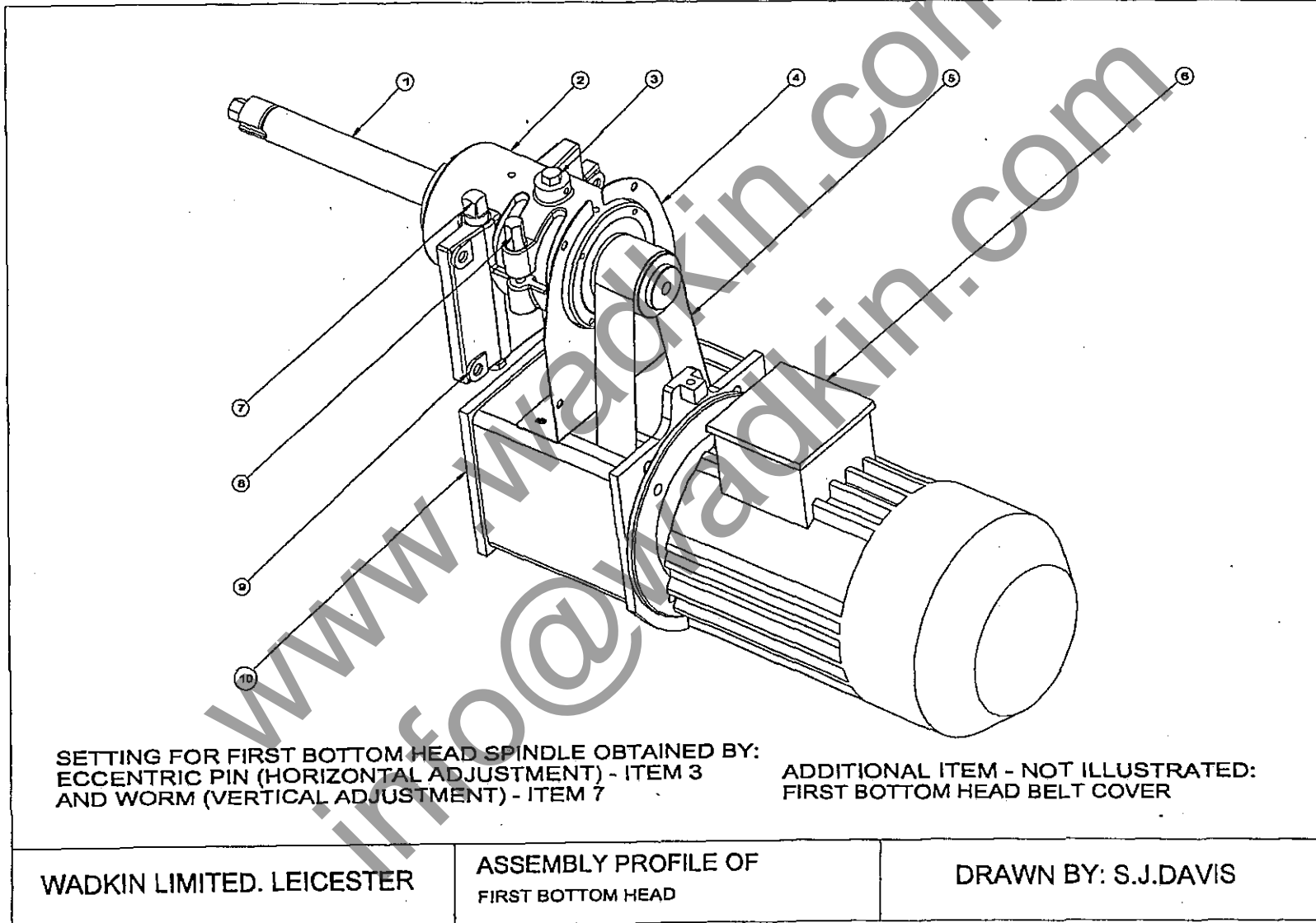

ILLUSTRATED PARTS LIST – MODEL K23  
WADKIN LIMITED, LEICESTER

DESCRIPTION: TOP IDLE ROLLER PRESSURE

REF. NO.	PART DESCRIPTION	QUANTITY
1	HORIZONTAL PRESSURE BAR FOR TRANSVERSE ADJUSTMENT	1
2	SPLIT CLAMP	1
3	SPRING TENSIONER FOR TOP PRESSURE	1
4	M12 WASHER	4
5	SPRING	1
6	M12 X 45mm HEXAGON HEAD SCREW	4
7	BARREL FOR TOP PRESSURE	1
8	ROLLER ARM FOR TOP PRESSURE	1
9	ROLLER PIN FOR TOP PRESSURE	1
10	HORIZONTAL PRESSURE BAR	1
11	SPLIT CLAMP FOR PRESSURE	1
12	8mm DIAMETER X 24mm LONG TENSION PIN	1
13	5mm DIAMETER X 24mm LONG TENSION PIN	1
14	BLACK POLYURETHANE ROLLER INCLUDING BEARING	1
15	20mm DIAMETER EXTERNAL CIRCLIP	1
16	M10 X 55mm HEXAGON HEAD SCREW	1
17	BRACKET FOR TOP PRESSURE	1
18	M10 X 35mm HEXAGON SOCKET CAPSCREW	2
19	M10 WASHER	1
20	M10 SPRING WASHER SINGLE COIL	1
21	M10 HEXAGON NUT	1



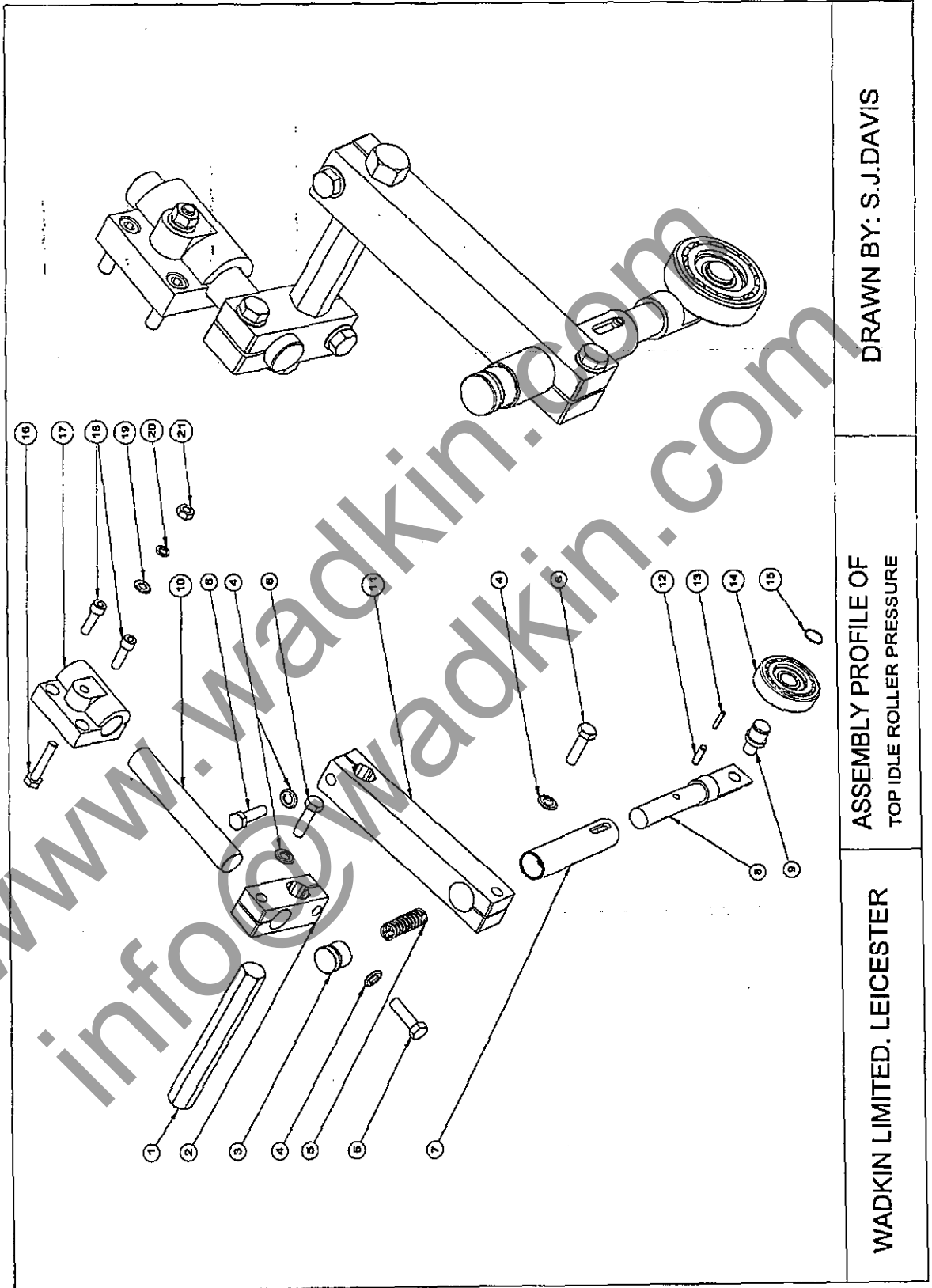

DRAWN BY: S.J.DAVIS

ASSEMBLY PROFILE OF  
TOP IDLE ROLLER PRESSURE

WADKIN LIMITED. LEICESTER

ILLUSTRATED PARTS LIST – MODEL K23  
WADKIN LIMITED, LEICESTER

DESCRIPTION: BELT ARRANGEMENT (NEAR SIDE HEAD/FENCE SIDE HEAD SPINDLE)

REF. NO.	PART DESCRIPTION	QUANTITY
1	NEAR SIDE HEAD CARRIAGE	1
2	FENCE SIDE HEAD AND NEAR SIDE HEAD DRIVE BELT	1
3	BELT TENSIONER IDLE ROLLER	1
4	SHAFT FOR IDLE ROLLER	1
5	6305-2RS RHP & SKF BEARING	1
6	6206-2RS SKF BEARING	1
7	PIVOT PIN FOR IDLE ROLLER LINK	1
8	TENSIONER PIVOT BRACKET	1
9	PIVOT LINK FOR IDLE ROLLER	1
10	14.28.175.450.EE.1500N GAS SPRING	1
11	FIXING BLOCK FOR GAS SPRING	1
12	GAS SPRING ANCHOR	1
13	FENCE SIDE HEAD CARRIAGE	1
14	MOTOR PULLEY	1
15	TAPER LOCK BUSH	1
16	FENCE SIDE HEAD AND NEAR SIDE HEAD MOTOR	1

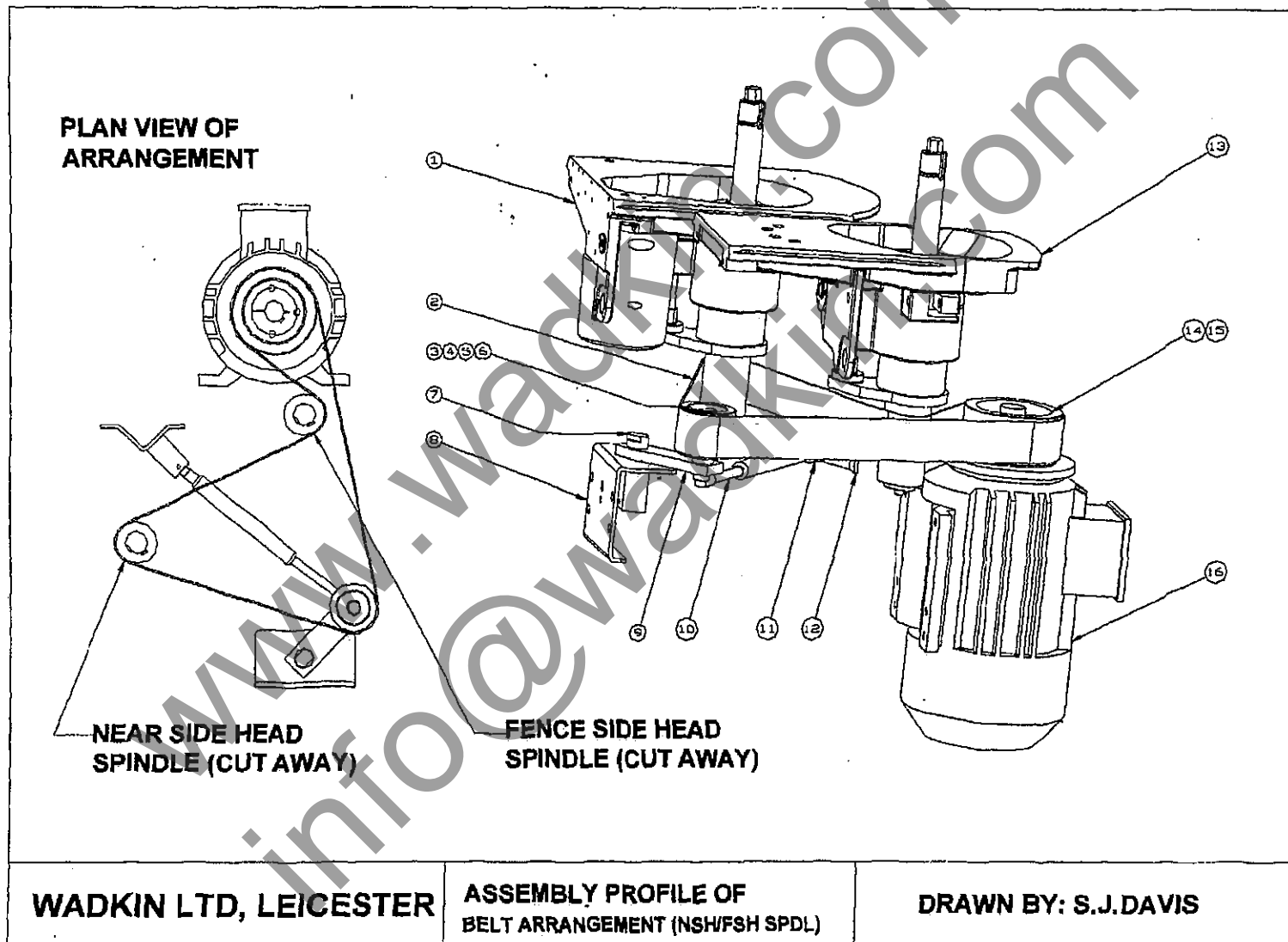

WADKIN LTD, LEICESTER

ASSEMBLY PROFILE OF BELT ARRANGEMENT (NSH/FSH SPDL)

DRAWN BY: S.J.DAVIS

ILLUSTRATED PARTS LIST – MODEL K23  
WADKIN LIMITED, LEICESTER

DESCRIPTION: FENCE SIDE HEAD CARRIAGE

REF. NO.	PART DESCRIPTION	QUANTITY
1	BARREL CLAMPING STUD	1
2	M12 HEXAGON LOCKNUT	4
3	M12 WASHER LARGE DIAMETER	2
4	25mm OD X 12.2mm ID DISC SPRING	12
5	M12 WASHER	1
6	BEDPLATE BETWEEN FENCE SIDE HEAD AND NEAR SIDE HEAD	1
7	FENCE SIDE HEAD CARRIAGE	1
8	FENCE SIDE HEAD BEDPLATE	1
9	BEDPLATE ADJUSTMENT SCREW FOR FENCE SIDE HEAD	1
10	VCT63B-M12 LOBE KNOB	1
11	BLOCK FOR FENCE SIDE HEAD BEDPLATE ADJUSTMENT	1
12	PNEUMATIC CYLINDER	1
13	PIVOT PAR	1
14	PIVOT LOCK BLOCK	1
15	PUSH PLATE	1
16	FENCE SIDE HEAD HOOD	1
17	BEDPLATE AFTER FIRST BOTTOM HEAD	1

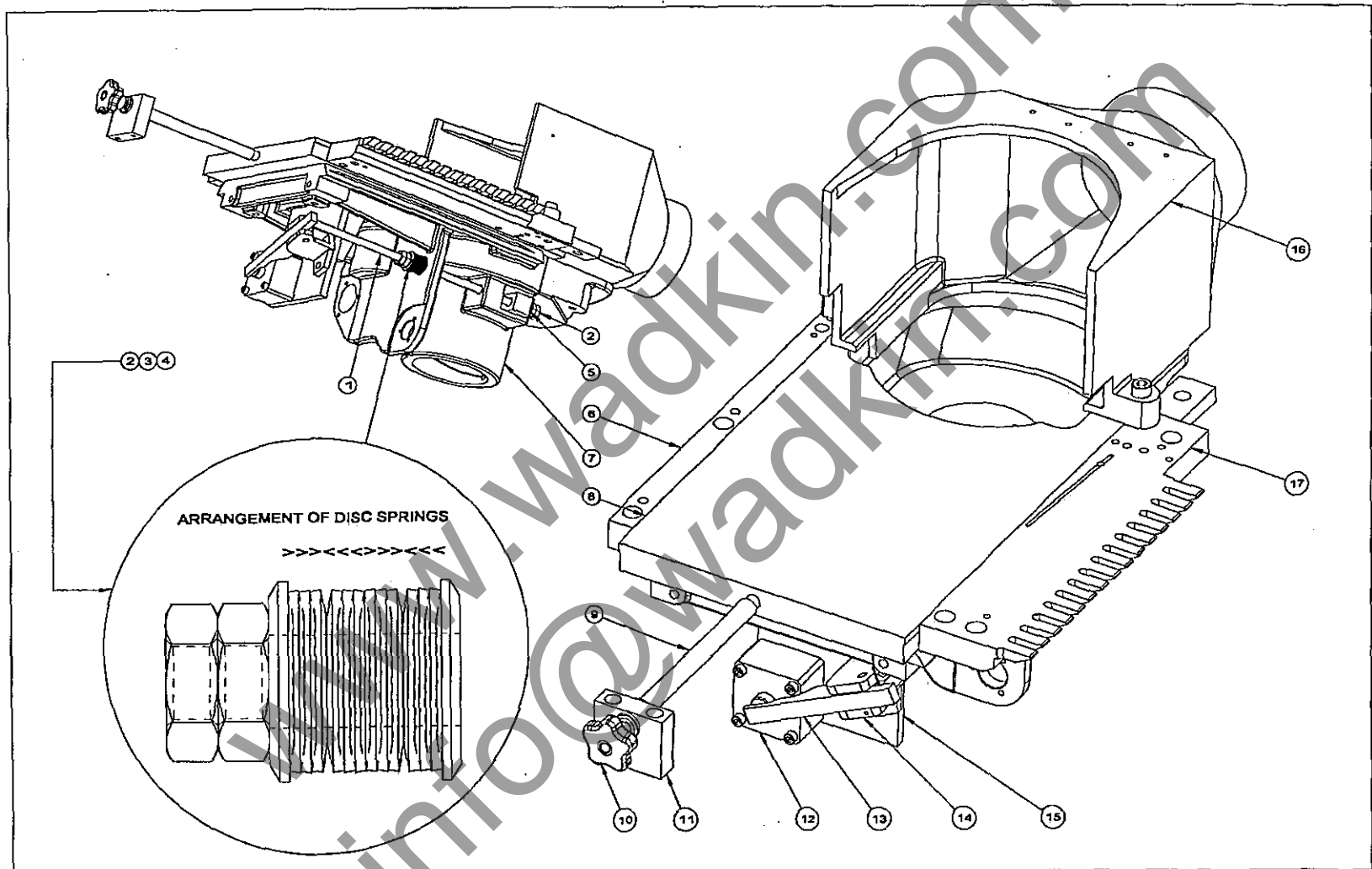

WADKIN LIMITED. LEICESTER

ASSEMBLY PROFILE OF  
FENCE SIDE HEAD CARRIAGE

DRAWN BY: S.J.DAVIS

ILLUSTRATED PARTS LIST – MODEL K23  
WADKIN LIMITED, LEICESTER

DESCRIPTION: NEAR SIDE HEAD CARRIAGE

REF. NO.	PART DESCRIPTION	QUANTITY
1	NEAR SIDE HEAD BEDPLATE	1
2	ARM CARRYING PRESSURE AFTER NEAR SIDE HEAD	1
3	PRESSURE SHOE AFTER NEAR SIDE HEAD	1
4	BRACKET CARRYING PRESSURE AFTER NEAR SIDE HEAD	1
5	ADJUSTING NUT FOR NEAR SIDE HEAD BEDPLATE	1
6	NEAR SIDE HEAD BEDPLATE ADJUSTING SCREW	1
7	NEAR SIDE HEAD BEDPLATE ADJUSTING BRACKET	1
8	VCT63B M12 LOBE KNOB	1
9	NEAR SIDE HEAD CARRIAGE	1
10	HOOD LOCATION PIN	1
11	END CAP FOR NEAR SIDE HEAD CARRIAGE	1
12	BUSH FOR BARREL CLAMP	1
13	NEAR SIDE HEAD CHIP DEFLECTOR	1
14	NEAR SIDE HEAD CHIPBREAKER SHOE	1
15	STANDARD SPRING NO. 3	2
16	CHIPBREAKER PIVOT PIN	1
17	ROLLER PIN FOR SIDE PRESSURE	2
18	EXTERNAL CIRCLIP 20mm DIAMETER	2
19	ROLLER ARM FOR SIDE PRESSURE	2
20	BLACK POLYURETHANE ROLLER INCLUDING BEARING	2
21	NEAR SIDE HEAD CHIPBREAKER/ROLLER CARRIER	1
22	SPRING TENSIONER FOR SIDE PRESSURE	2
23	SPRING	2
24	KEY FOR NEAR SIDE HEAD CHIPBREAKER	1
25	PLATE CARRYING NEAR SIDE HEAD ROLLER PRESSURE	1

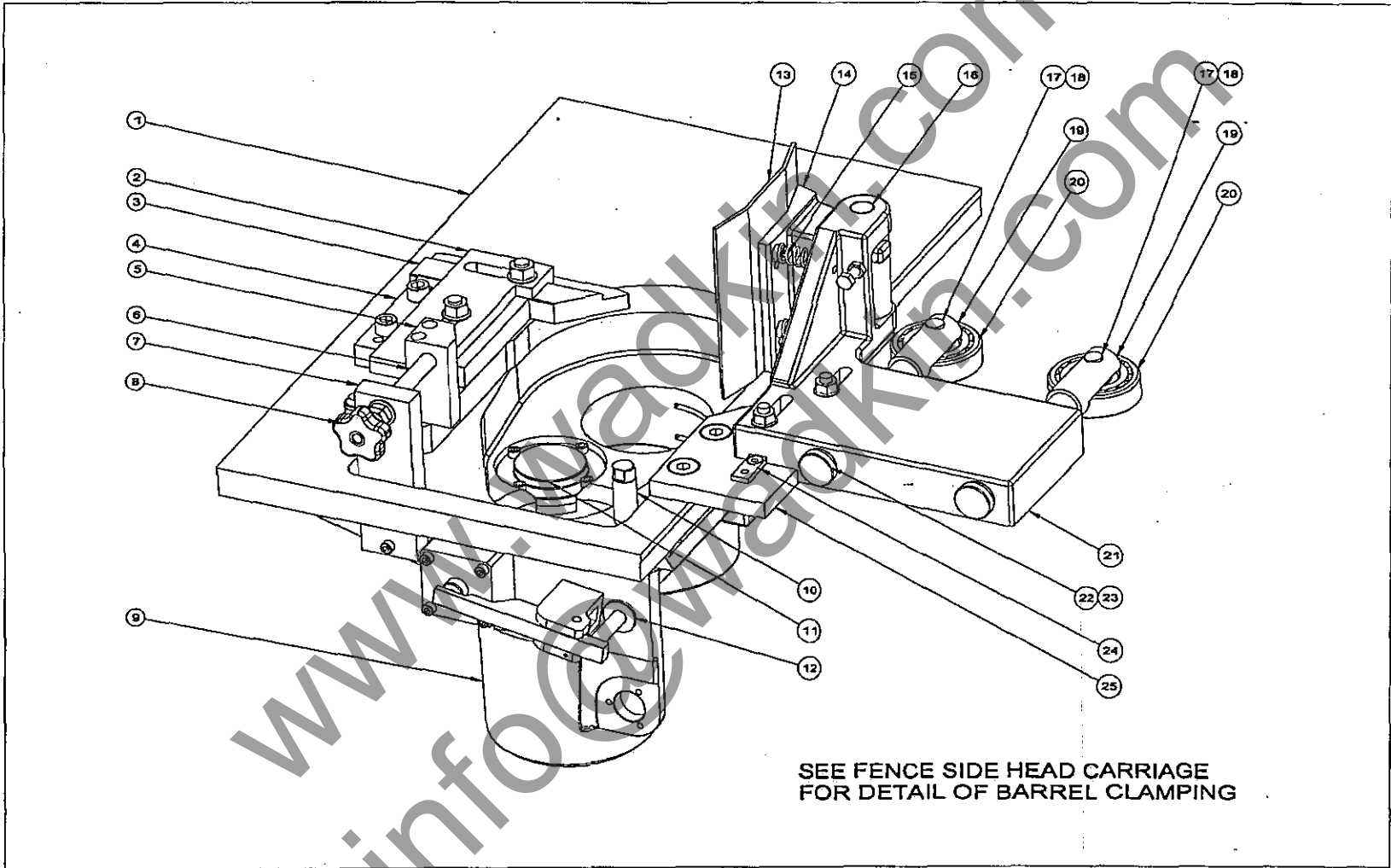

WADKIN LIMITED. LEICESTER

ASSEMBLY PROFILE OF  
NEAR SIDE HEAD CARRIAGE

DRAWN BY: S.J.DAVIS

ILLUSTRATED PARTS LIST – MODEL K23  
WADKIN LIMITED, LEICESTER

DESCRIPTION: FENCE SIDE HEAD & NEAR SIDE HEAD LATERAL ADJUSTMENT GEARBOX

REF. NO.	PART DESCRIPTION	QUANTITY
1	M20 NOTCH NUT	2
2	LS-2035 INA THRUST WASHER	4
3	AXK-2035 INA THRUST BEARING	2
4	20mm ID X 25mm OD X 20mm LONG BUSH	1
5	BARREL RISE AND FALL SCREW BEARING HOUSING	1
6	HELICAL GEAR FOR BARREL RISE AND FALL	1
7	BARREL RISE AND FALL SCREW	1
8	6mm X 6mm X 20mm LONG KEY	1
9	25mm ID X 30mm OD X 20mm LONG BUSH	2
10	AS-2542 INA THRUST WASHER	2
11	AXK-2542 INA THRUST BEARING	2
12	LS-2542 INA THRUST WASHER	2
13	HELICAL GEAR FOR BARREL RISE AND FALL	1
14	ADJUSTING NUT LEFT HANDED TRAPEZOIDAL	1
15	HELICAL GEAR BEARING HOUSING	1
16	M6 X 25mm SCREWED STUD	3
17	M6 HEXAGON LOCKNUT	3



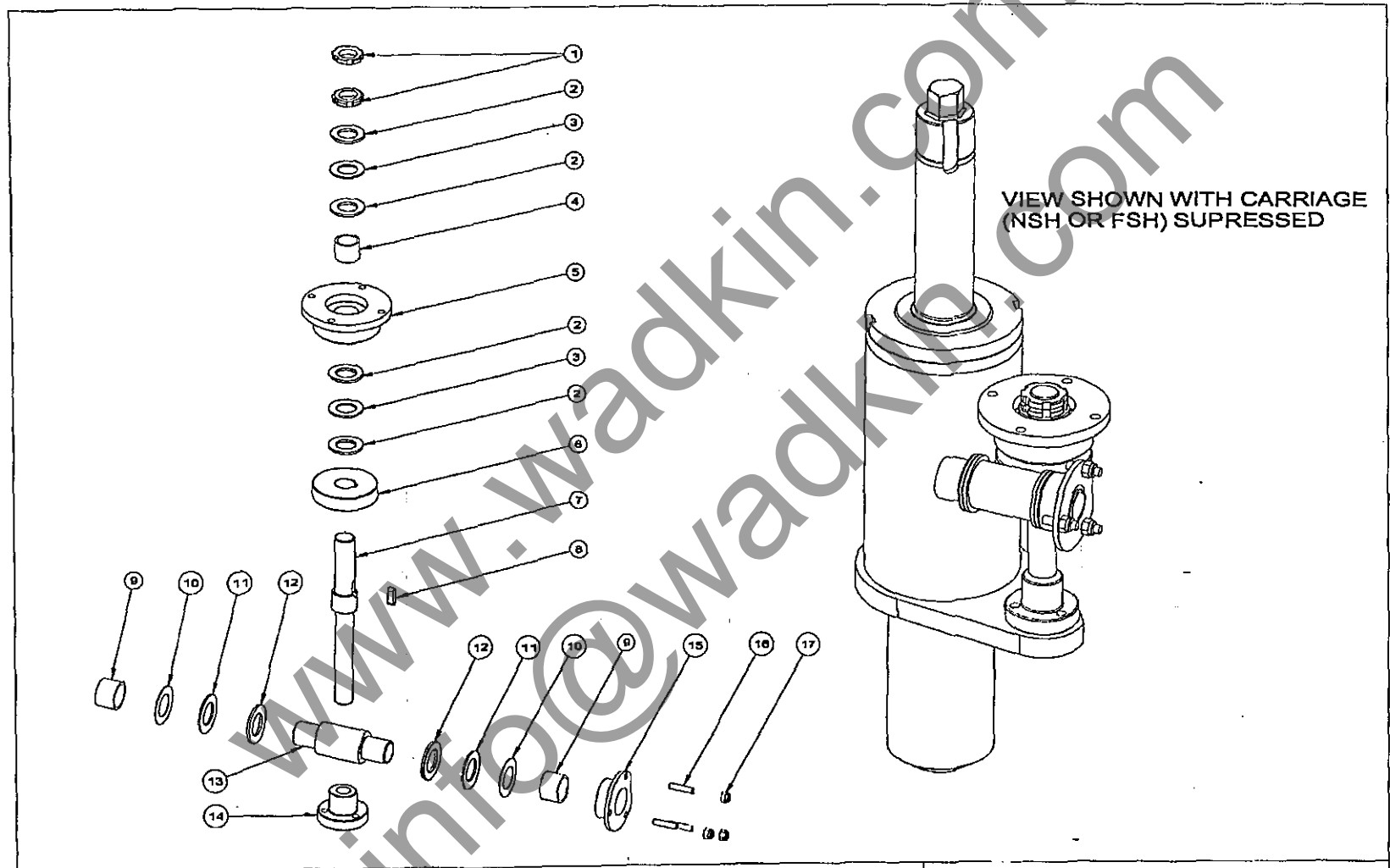

VIEW SHOWN WITH CARRIAGE  
(NSH OR FSH) SUPRESSED

WADKIN LIMITED. LEICESTER

ASSEMBLY PROFILE OF  
FSH & NSH LATERAL ADJ. GEARBOX

DRAWN BY: S.J.DAVIS

ILLUSTRATED PARTS LIST – MODEL K23  
WADKIN LIMITED, LEICESTER

DESCRIPTION: SIDE HEAD LOCKING ARRANGEMENT

REF. NO.	PART DESCRIPTION	QUANTITY
1	M10 X 16mm HEXAGON SOCKET CAPSCREW	1
2	SIDE HEAD LOCKING WEDGE	1
3	16mm ID X 20mm OD X 16mm LONG BUSH	1
4	16mm ID X 20mm OD X 25mm LONG BUSH	1
5	LOCKING HOUSING	1
6	LOCKING WEDGE	1
7	M10 X 30mm HEXAGON SOCKET CAPSCREW	1
8	SIDE HEAD LOCKING STUD	1
9	M12 WASHER	1
10	M12 HEXAGON LOCKNUT	1
11	SIDE HEAD LOCKING STUD	1
12	NEAR SIDE HEAD CARRIAGE	1
13	FLANGED BUSH FOR LOCKING SHAFT	1
14	M10 X 30mm MALE ADJUSTING HANDLE	1

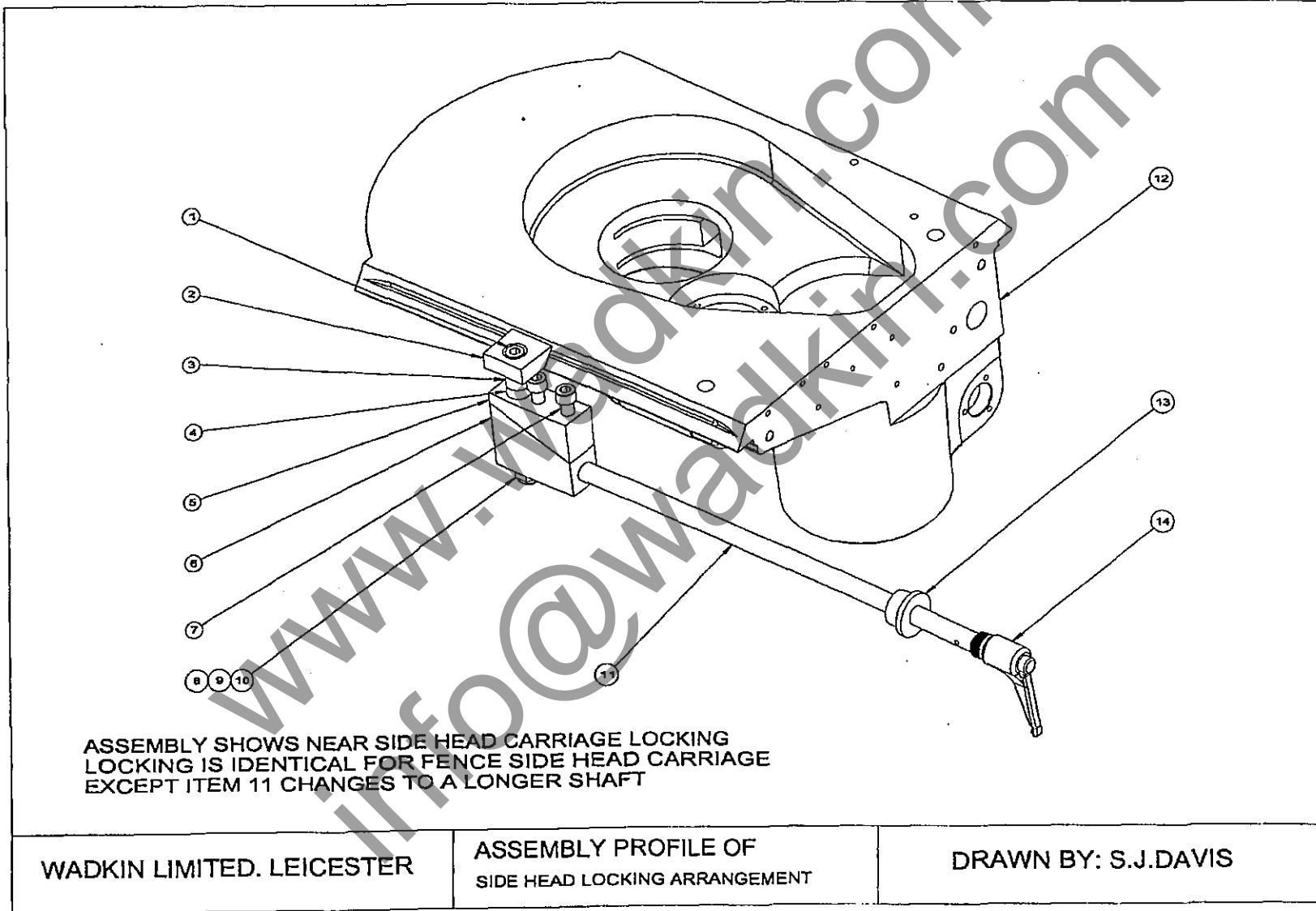

ILLUSTRATED PARTS LIST – MODEL K23  
WADKIN LIMITED, LEICESTER

DESCRIPTION: TOP HEAD ADJUSTMENT

REF. NO.	PART DESCRIPTION	QUANTITY
1	6mm X 25mm LONG PLAIN DOWEL	2
2	20mm ID X 25mm OD X 20mm LONG BUSH	2
3	20mm ID X 25mm OD X 25mm LONG BUSH	2
4	INPUT SHAFT	1
5	DA10R-12.2.E.25.A1.S, SIKO DUAL READOUT CLOCK	1
6	LS-2035 INA THRUST WASHER	4
7	AXK-2035 INA THRUST BEARING	2
8	BEARING HOUSING FOR HEAD ADJUSTMENT SHAFTS	2
9	AXZ 8,20,35.4 NADELLA BEARING	2
10	M20 NOTCH NUT	4
11	INPUT SHAFT	1
12	DA1012-4-4,0-E-B-B-1-S, SIKO SINGLE READOUT CLOCK	1
13	UNIVERSAL JOINT FOR TOP HEAD RISE AND FALL LOCKING	1
14	TOP HEAD MOUNTING	1
15	UNIVERSAL JOINT FOR TOP HEAD AXIAL ADJUSTMENT	1
16	LOCKING STUD FOR RISE AND FALL	1
17	LOCKING PAD	1
18	UNIVERSAL JOINT FOR TOP HEAD RISE AND FALL	1

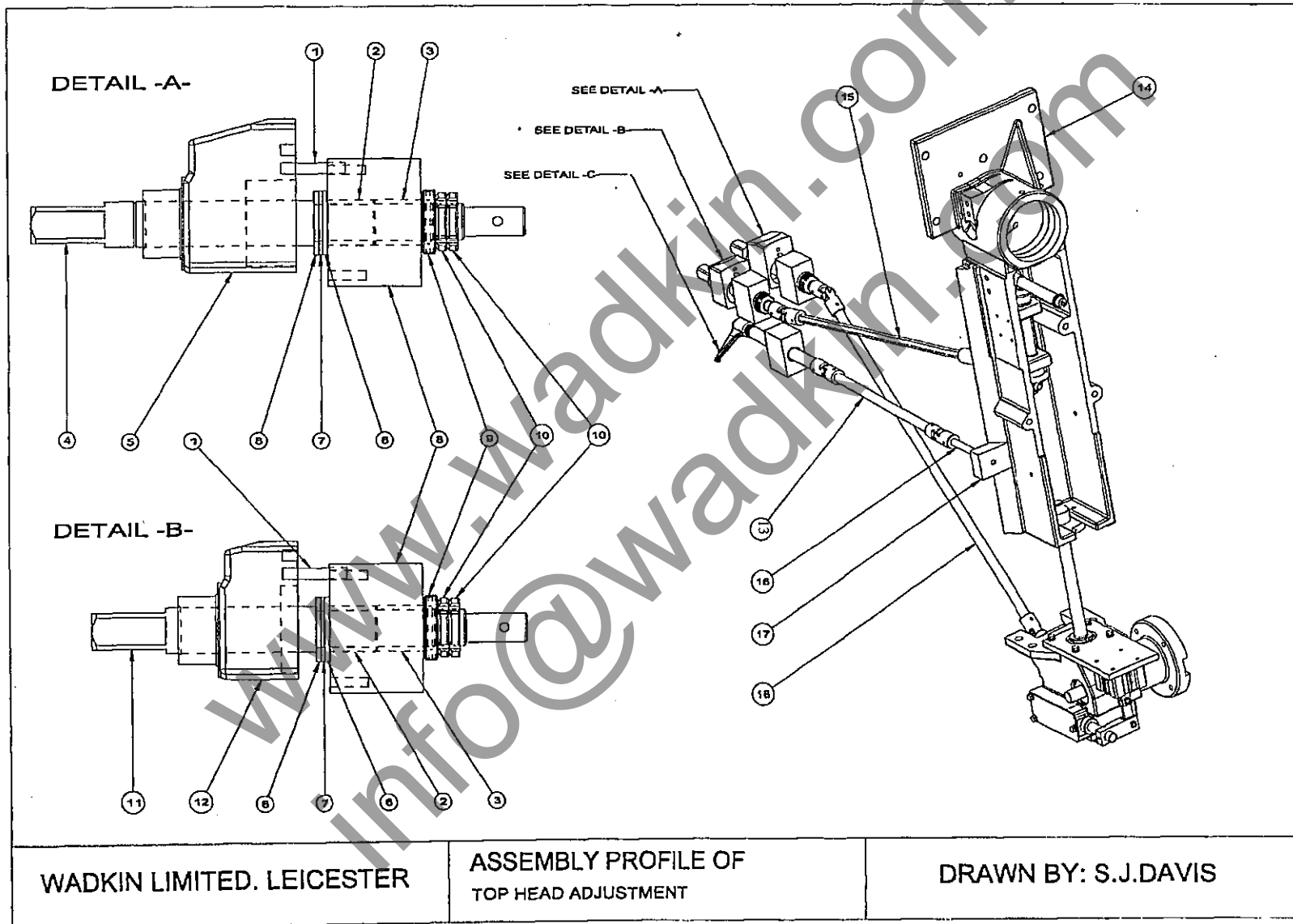

WADKIN LIMITED. LEICESTER

ASSEMBLY PROFILE OF  
TOP HEAD ADJUSTMENT

DRAWN BY: S.J.DAVIS

ILLUSTRATED PARTS LIST – MODEL K23  
WADKIN LIMITED, LEICESTER

DESCRIPTION: TOP HEAD RISE & FALL BEVEL BOX

REF. NO.	PART DESCRIPTION	QUANTITY
1	M6 X 70mm HEXAGON SOCKET CAPSCREW	4
2	M6 SPRING WASHER SINGLE COIL	12
3	ADAPTOR FOR MOTOR/GEAR HOUSING	1
4	COUPLING FOR RISE AND FALL MOTOR	1
5	47mm DIAMETER INTERNAL CIRCLIP	2
6	6204-2RS RHP & SKF BEARING	2
7	WORM FOR TOP HEAD RISE AND FALL	1
8	WORMGEAR AND CLUTCH HOUSING	1
9	NUT FOR TOP HEAD RISE AND FALL	1
10	BEVEL GEAR FOR TOP HEAD RISE AND FALL	1
11	71.5mm OD X 45.5mm ID X 0.7mm DISC SPRING	1
12	M24 NOTCH NUT	1
13	M6 X 20mm HEXAGON HEAD SCREW	4
14	M6 WASHER	9
15	CYLINDER MOUNTING BRACKET	1
16	PNEUMATIC CYLINDER	1
17	M6 X 40mm HEXAGON SOCKET CAPSCREW	4
18	30mm ID X 35mm OD X 20mm LONG BUSH	1
19	8mm DIAMETER E RETAINING CIRCLIP	4
20	CYLINDER CLEVIS	1
21	CLUTCH LOCATION ARM	1
22	CLEVIS PIN	2
23	5mm X 5mm X 20mm LONG KEY	1
24	M6 X 25mm HEXAGON SOCKET CAPSCREW	3
25	END CAP FOR RISE AND FALL BEVEL BOX	1
26	20mm ID X 25mm OD X 25mm LONG BUSH	1

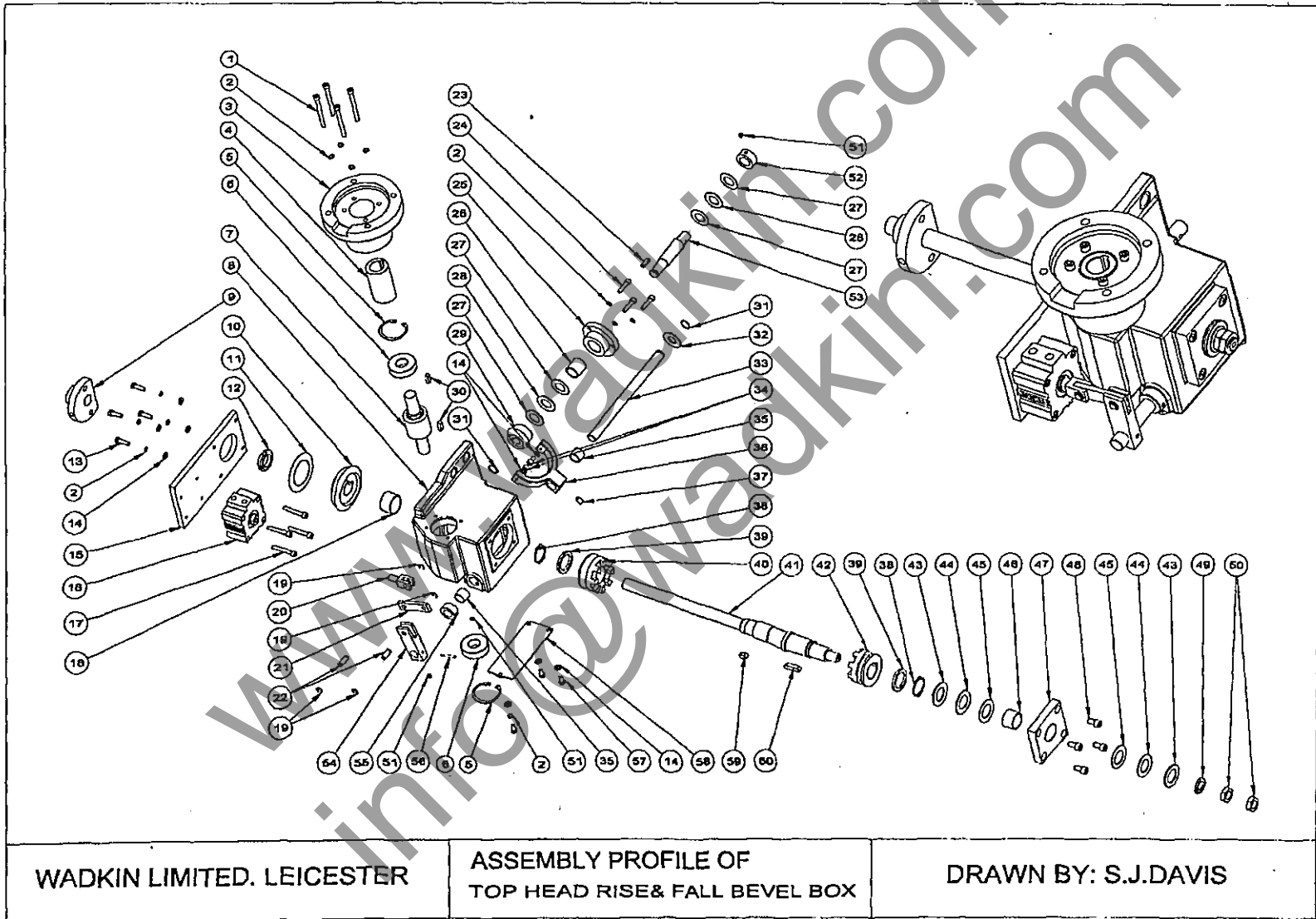

WADKIN LIMITED. LEICESTER

ASSEMBLY PROFILE OF  
TOP HEAD RISE & FALL BEVEL BOX

DRAWN BY: S.J.DAVIS

ILLUSTRATED PARTS LIST – MODEL K23  
WADKIN LIMITED, LEICESTER

DESCRIPTION: TOP HEAD RISE & FALL BEVEL BOX

REF. NO.	PART DESCRIPTION	QUANTITY
27	AS-2035 INA THRUST WASHER	4
28	AXK-2035 INA THRUST BEARING	2
29	BEVEL GEAR FOR TOP HEAD RISE AND FALL	1
30	6mm X 6mm X 20mm LONG KEY	2
31	EXTERNAL CIRCLIP 16mm DIAMETER	2
32	M16 LARGE DIAMETER WASHER	1
33	PIVOT SHAFT	1
34	M6 X 10mm HEXAGON SOCKET CAPSCREW	2
35	16mm ID X 20mm OD X 16mm LONG BUSH	2
36	CLUTCH YOKE	1
37	HEXAGON SOCKET SCREW – HALF DOG POINT	1
38	30mm DIAMETER EXTERNAL CIRCLIP	2
39	CLUTCH SPACER	2
40	WORMWHEEL FOR TOP HEAD RISE AND FALL	1
41	TOP HEAD RISE AND FALL SCREW	1
42	TOP HEAD RISE AND FALL CLUTCH	1
43	LS-2542 INA THRUST WASHER	2
44	AXK-2542 INA THRUST BEARING	2
45	AS-2542 INA THRUST WASHER	2
46	25mm ID X 30mm OD X 20mm LONG BUSH	1
47	COVER FOR WORMBOX	1
48	M8 X 16mm HEXAGON SOCKET CAPSCREW	4
49	M16 WASHER	1
50	M16 HEXAGON LOCKNUT	2
51	M6 X 6mm GRUBSCREW	3
52	20mm ID X 32mm OD X 14mm LONG COLLAR	1



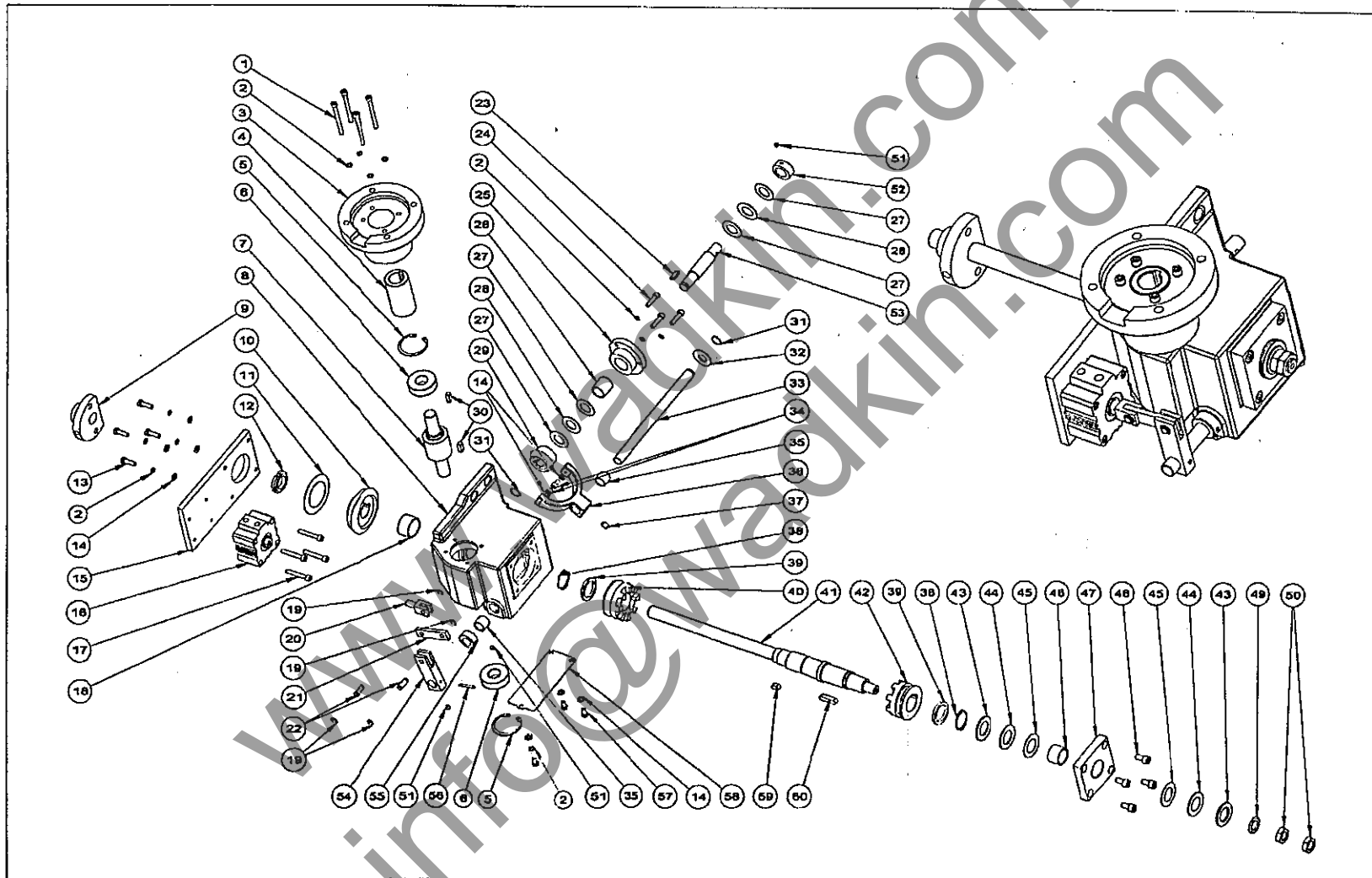

WADKIN LIMITED. LEICESTER

ASSEMBLY PROFILE OF  
TOP HEAD RISE & FALL BEVEL BOX

DRAWN BY: S.J.DAVIS

ILLUSTRATED PARTS LIST -- MODEL K23  
WADKIN LIMITED, LEICESTER

DESCRIPTION: TOP HEAD RISE &amp; FALL BEVEL BOX

REF. NO.	PART DESCRIPTION	QUANTITY
53	MANUAL INPUT SHAFT	1
54	CLUTCH ARM	1
55	16mm ID X 25mm OD X 12mm LONG COLLAR	1
56	STANDARD TAPER PIN NO. 1	1
57	M6 X 12mm HEXAGON HEAD SCREW	3
58	COVER FOR WORMBOX	1
59	8mm X 7mm X 14mm LONG KEY	1
60	8mm X 7mm X 32mm LONG KEY	1

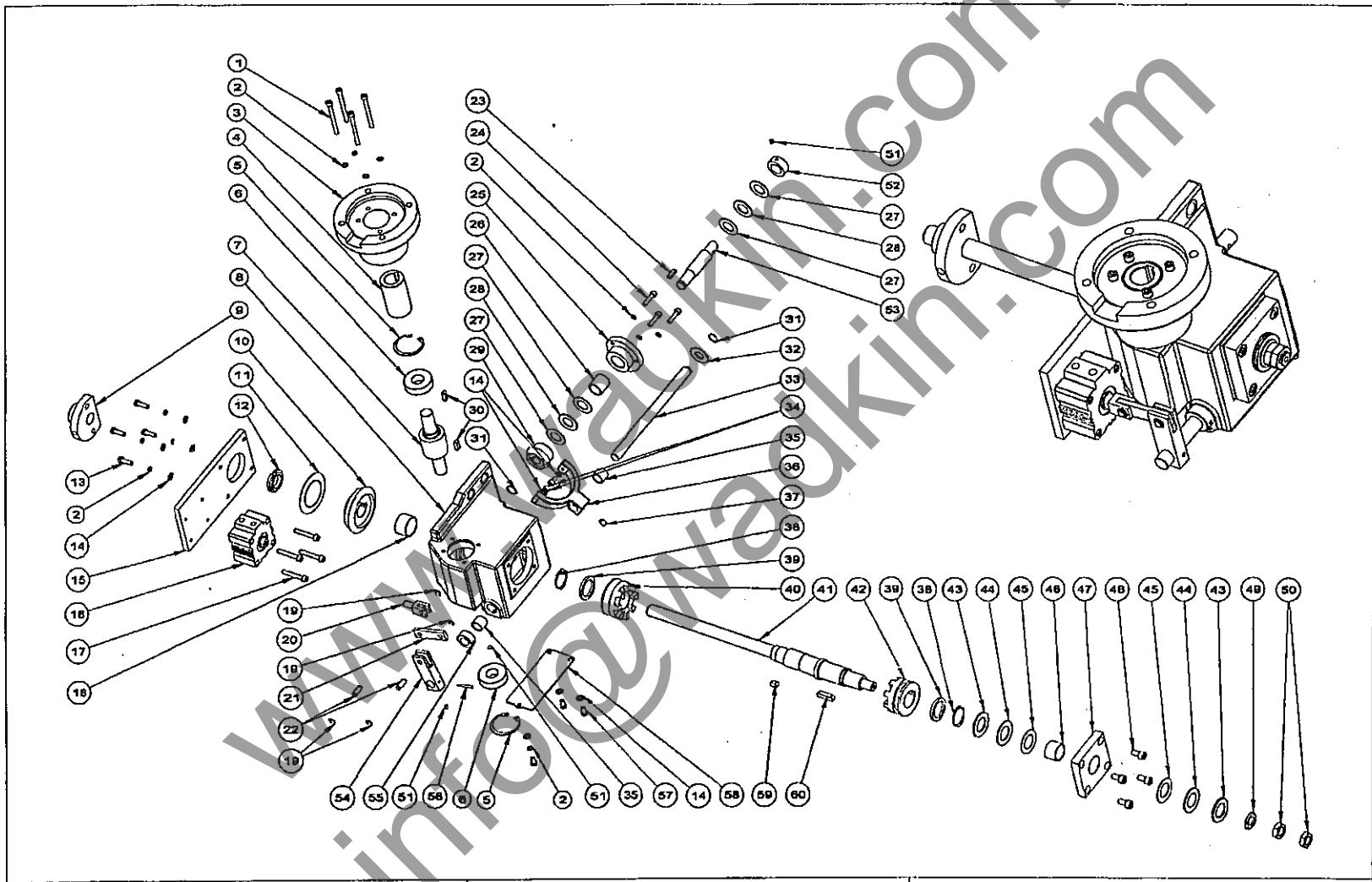

WADKIN LIMITED. LEICESTER

ASSEMBLY PROFILE OF  
TOP HEAD RISE & FALL BEVEL BOX

DRAWN BY: S.J.DAVIS

ILLUSTRATED PARTS LIST – MODEL K23  
WADKIN LIMITED, LEICESTER

DESCRIPTION: TOP/SECOND BOTTOM SPINDLE AXIAL ADJUSTMENT

REF. NO.	PART DESCRIPTION	QUANTITY
1	5mm X 5mm X 20mm LONG KEY	4
2	M12 HEXAGON LOCKNUT	1
3	LS-1226 INA THRUST WASHER	2
4	AXK-1226 INA NEEDLE RACE	1
5	BEVEL GEAR BRACKET	1
6	16mm ID X 20mm OD X 16mm LONG BUSH	3
7	RHP 51103 THRUST BEARING	3
8	STRAIGHT MITRE BEVEL GEAR	4
9	AXIAL CONNECTING SHAFT	1
10	LS-1730 INA THRUST WASHER	2
11	AXK-1730 INA THRUST BEARING	1
12	16mm ID X 20mm OD X 25mm LONG BUSH	1
13	AXIAL ADJUSTMENT BEVEL GEAR SHAFT	1
14	AXIAL ADJUSTMENT SCREW	1
15	M10 WASHER LARGE DIAMETER	1
16	HEXAGON SOCKET CAPSCREW M10 X 20mm	1
17	M10 WASHER	1
18	M10 HEXAGON LOCKNUT	1
19	M10 X 30mm HEXAGON SOCKET CAPSCREW	2

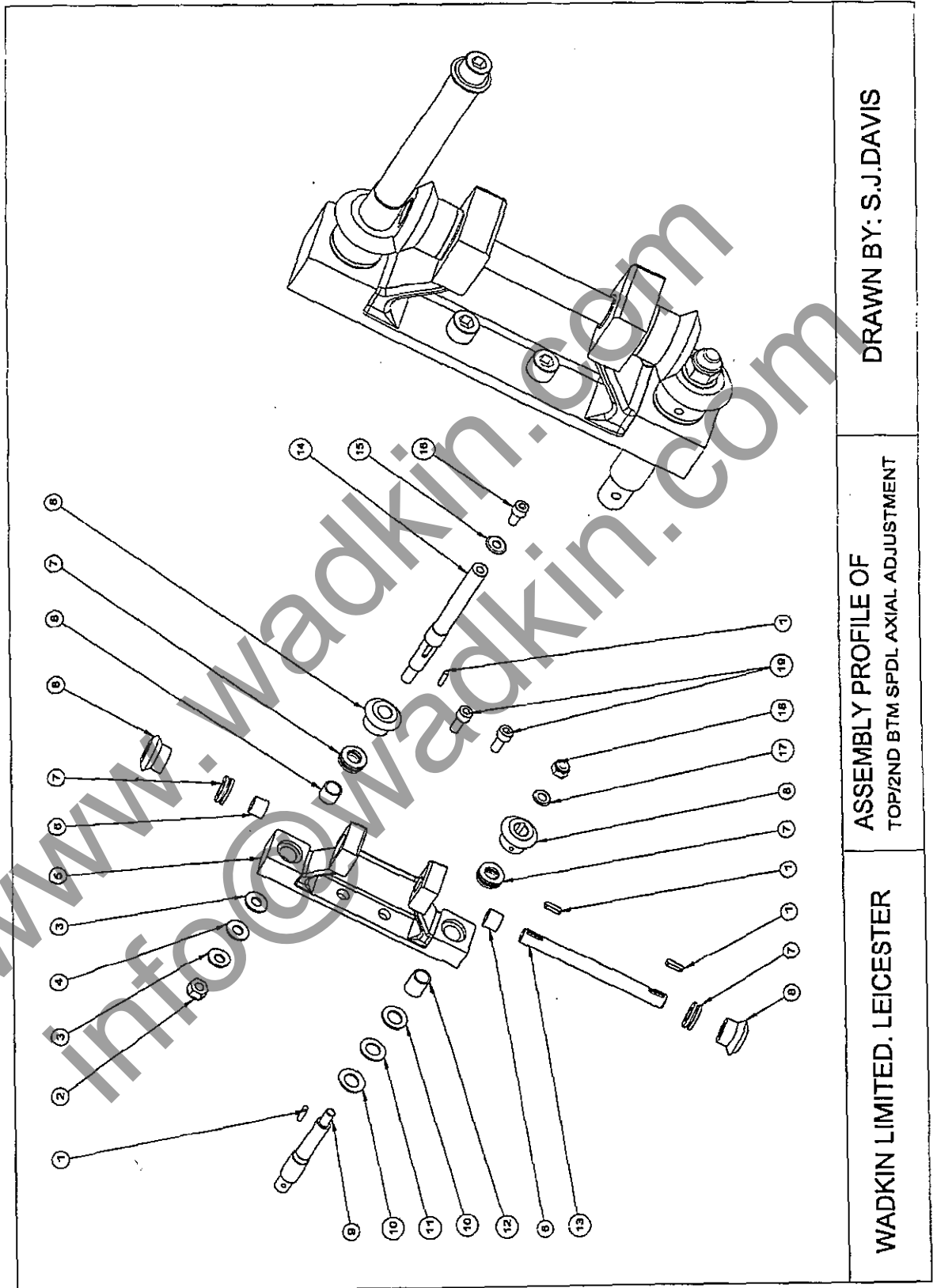

DRAWN BY: S.J.DAVIS

ASSEMBLY PROFILE OF  
TOP/2ND BTM SPDL AXIAL ADJUSTMENT

WADKIN LIMITED. LEICESTER

ILLUSTRATED PARTS LIST – MODEL K23  
WADKIN LIMITED, LEICESTER

DESCRIPTION: TOP HEAD CHIPBREAKER

REF. NO.	PART DESCRIPTION	QUANTITY
1	LC-105M-10 COMPRESSION SPRING	2
2	CHIP DEFLECTOR	2
3	RADIAL CHIPBREAKER SHOE	2
4	M20 NOTCH NUT	4
5	92037701 CB DISC SPRING	12
6	ADJUSTING NUT FOR SPRING PRESSURE	2
7	STUD FOR SPRING PRESSURE	2
8	SPRING CAP	2
9	10mm ID X 14mm OD X 16mm LONG BUSH	2
10	PIN FOR EYE JOINT	2
11	TOP PIVOT LINK	2
12	16mm ID X 20mm OD X 16mm LONG BUSH	8
13	SHORT PIVOT BAR	2
14	TOP BEARING PIN	2
15	20mm ID X 25mm OD X 20mm LONG BUSH	4
16	LONG PIVOT BAR	2
17	BOTTOM PIVOT LINK	2
18	BOTTOM BEARING PIN	2
19	RADIAL CHIPBREAKER	1
20	19 A/F HEXAGON END	1
21	0304E 1.75mm SIKO INDICATOR	1
22	CHIPBREAKER LEADSCREW MOUNTING PLATE	1
23	CHIPBREAKER RISE AND FALL LEADSCREW	1
24	LOCKING NUT FOR CHIPBREAKER RISE AND FALL	2
25	TOP HEAD HOOD	1
26	CHIPBREAKER BODY	1

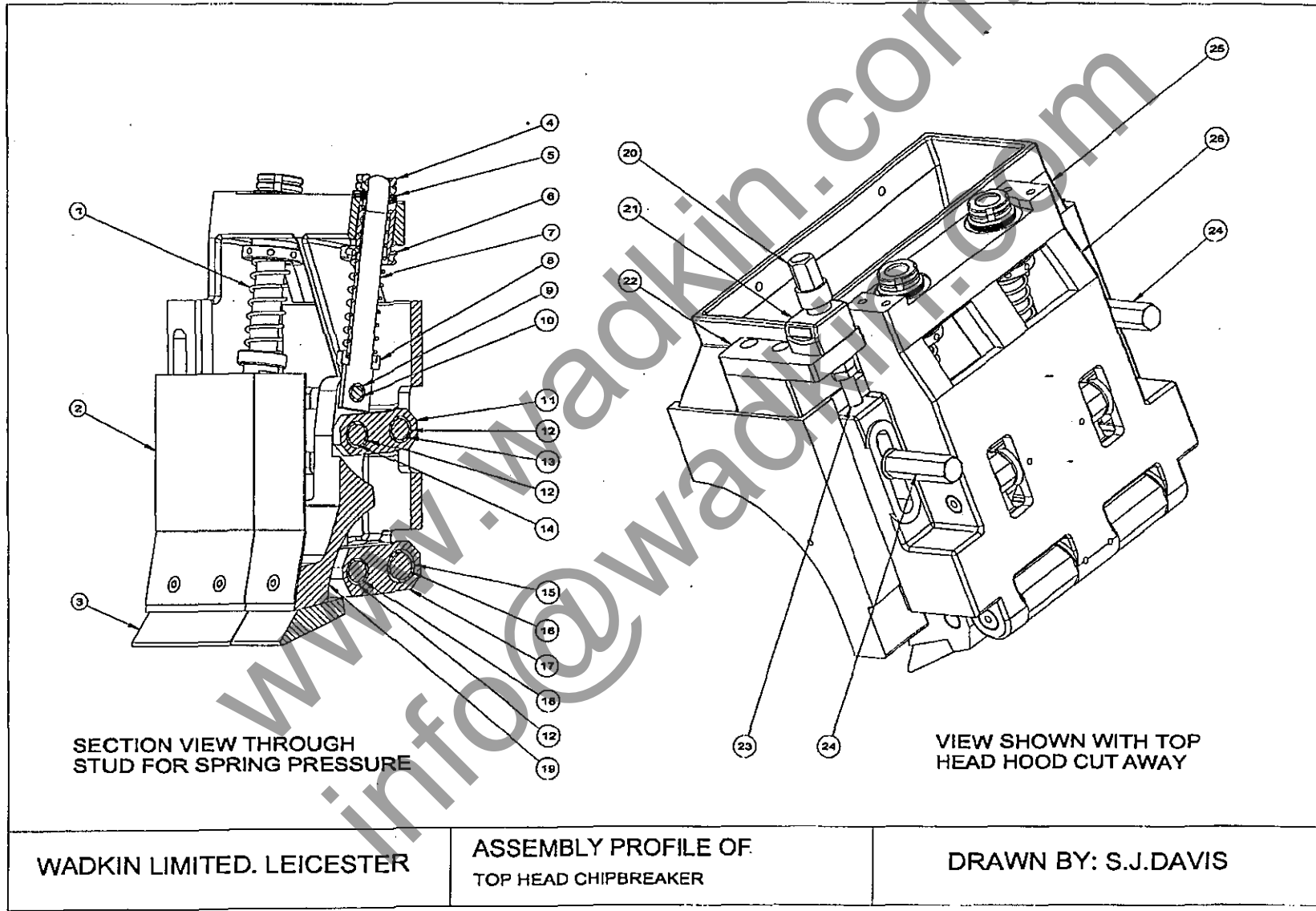

ILLUSTRATED PARTS LIST – MODEL K23  
WADKIN LIMITED, LEICESTER

DESCRIPTION: TOP HEAD PAD PRESSURE (SINGLE)

REF. NO.	PART DESCRIPTION	QUANTITY
1	TOP HEAD HOOD	1
2	283824 FLEXO COMPRESSION SPRING	1
3	M12 WASHER	2
4	WEAR STRIP FOR PAD PRESSURE	1
5	SCREW FOR TOP HEAD PRESSURE	1
6	TOP PRESSURE SLIDE	1
7	CROSS TENON FOR PRESSURE PAD	1
8	TOP PRESSURE SHOE	1
9	M10 TEE NUT WDS.664.203	1
10	VCT50B-M10 LOBE KNOB	1
11	M10 HEXAGON LOCKNUT	1
12	ADAPTOR FOR SIKO INDICATOR	1
13	0304E 1.75mm SIKO INDICATOR	1
14	TOP PRESSURE PLATE	1
15	GIB STRIP FOR PAD PRESSURE	1



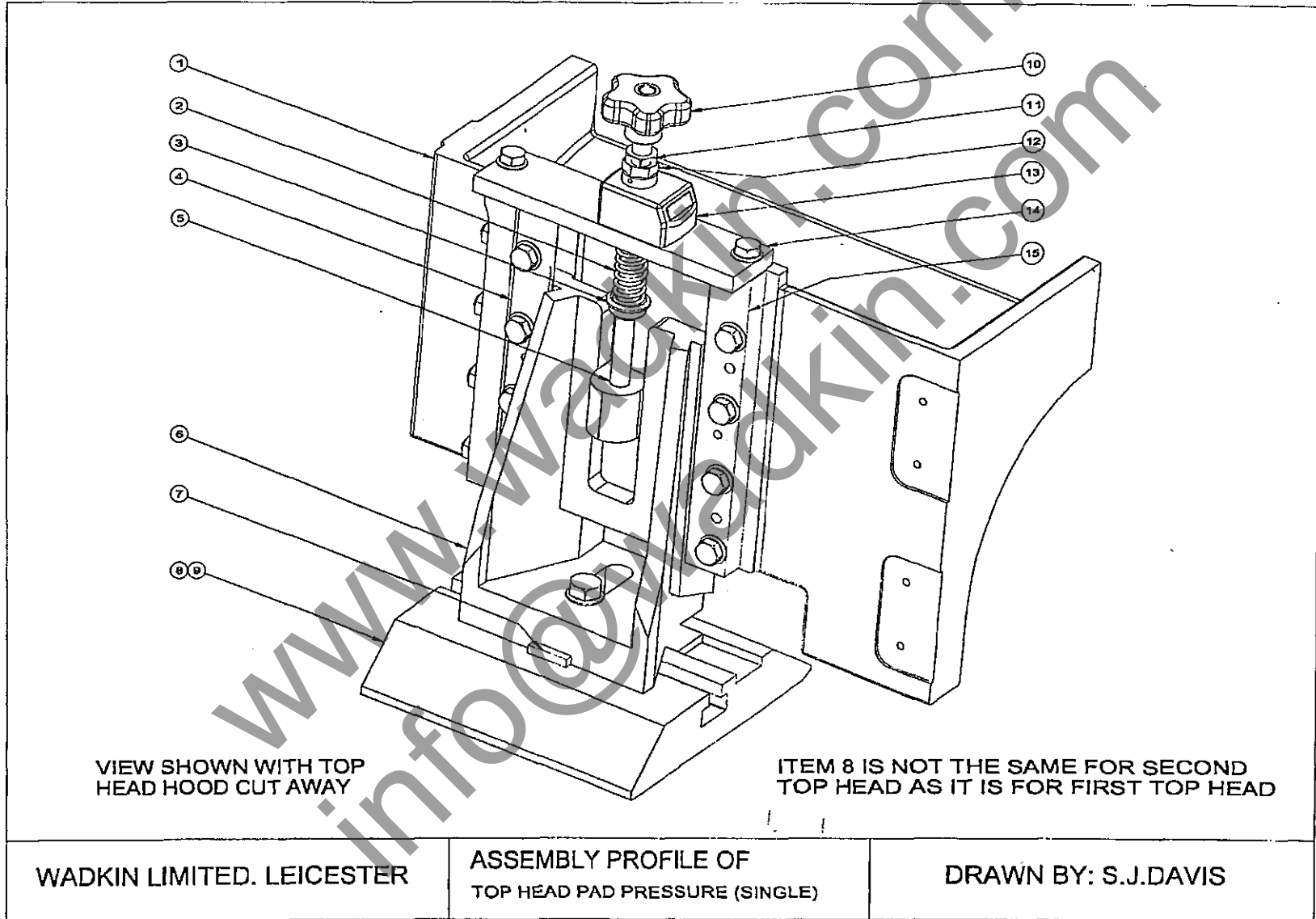

ILLUSTRATED PARTS LIST – MODEL K23  
WADKIN LIMITED, LEICESTER

DESCRIPTION: TOP HEAD PAD PRESSURE (SPLIT)

REF. NO.	PART DESCRIPTION	QUANTITY
1	VCT50B-M10 LOBE KNOB	2
2	M10 HEXAGON LOCKNUT	2
3	ADAPTOR FOR SIKO INDICATOR	2
4	0304E 1.75mm SIKO INDICATOR	2
5	283824 FLEXO COMPRESSION SPRING	2
6	M12 WASHER	4
7	SCREW FOR TOP HEAD PRESSURE	2
8	TOP HEAD HOOD	1
9	WEAR STRIP FOR PAD PRESSURE	1
10	DOUBLE VEE SLIDE	1
11	INNER TOP PRESSURE SLIDE	1
12	CROSS TENON FOR PRESSURE PAD	1
13	INNER TOP PRESSURE SHOE	1
14	M10 TEE NUT WDS.664.203	2
15	TOP PRESSURE PLATE	1
16	LOCATING STRIP FOR PAD PRESSURE	1
17	WEAR STRIP FOR PAD PRESSURE	1
18	OUTER TOP PRESSURE SLIDE	1
19	OUTER TOP PRESSURE SHOE	1
<p>SPLIT PAD PRESSURE FITS ONTO AN ADAPTOR PLATE (NO REF. NO. GIVEN) UNIT CAN BE RETRO-FITTED TO MACHINES WITH SINGLE PAD PRESSURE</p>		

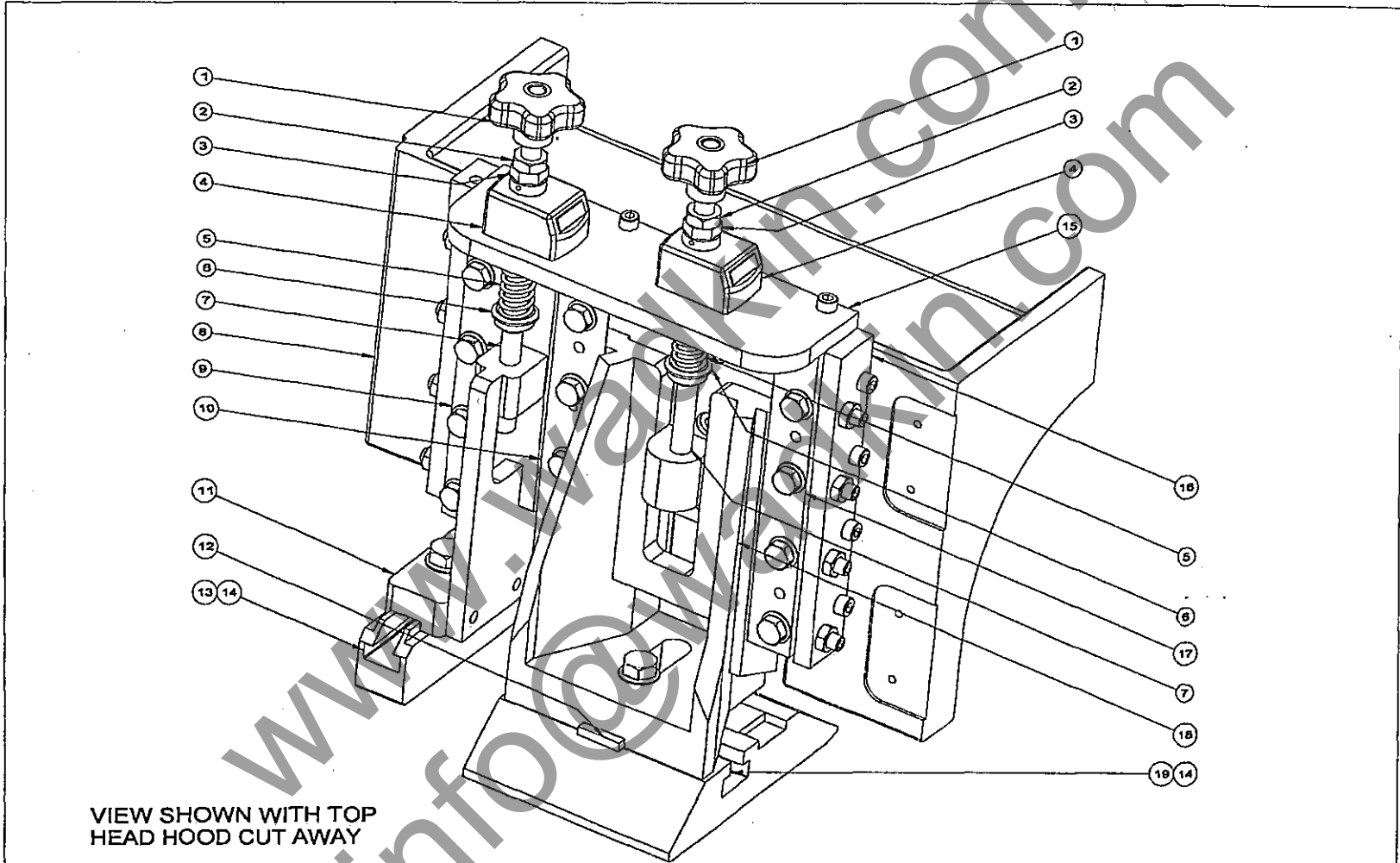

WADKIN LIMITED. LEICESTER

ASSEMBLY PROFILE OF  
TOP HEAD PAD PRESSURE (SPLIT)

DRAWN BY: S.J.DAVIS

ILLUSTRATED PARTS LIST – MODEL K23  
WADKIN LIMITED, LEICESTER

**DESCRIPTION: DRIVEN/IDLE BEDROLLER**

REF. NO.	PART DESCRIPTION	QUANTITY
1	20mm DIAMETER E RETAINING CIRCLIP	1
2	30mm DIAMETER EXTERNAL CIRCLIP	3
3	55mm DIAMETER INTERNAL CIRCLIP	1
4	6006-2RS RHP & SKF BEARING	2
5	SHAFT FOR BEDROLL	1
6	10mm X 8mm X 50mm LONG KEY	1
7	FEEDROLL – OUTFEED BOTTOM INNER	1
8	8mm X 20mm LONG PLAIN DOWEL	1
9	FEEDROLL – OUTFEED BOTTOM OUTER	1
10	PULLEY CLAMP WASHER	1
11	HEXAGON SOCKET CAPSCREW	1
12	SWING FOR BEDROLL	1
13	PIVOT SHAFT	1
14	20mm ID X 25mm OD X 30mm LONG INA INNER RING	2
15	8mm X 7mm X 36mm LONG KEY	1
16	HK25242RS INA SEALED NEEDLE BEARING	2
17	PNEUMATIC CYLINDER	1
18	M10 X 30mm HEXAGON HEAD SCREW	1
19	M10 HEXAGON LOCKNUT	3
20	M10 X 45mm GRUBSCREW	2
21	M10 X 12mm GRUBSCREW	1
22	M10 X 55mm HEXAGON SOCKET CAPSCREW	3
23	M10 WASHER	3
24	MOUNTING BRACKET FOR BEDROLL	1

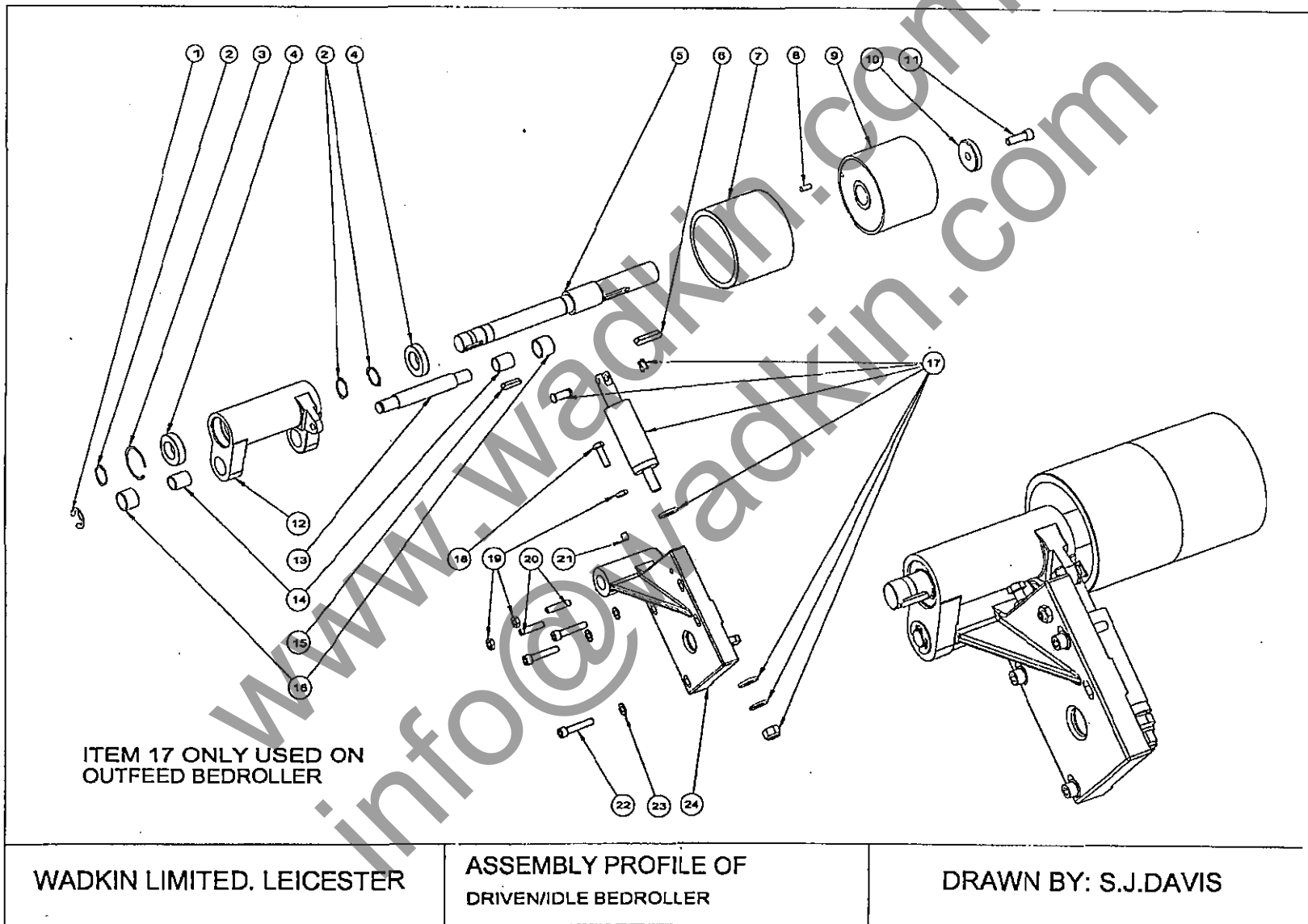

ILLUSTRATED PARTS LIST – MODEL K23  
WADKIN LIMITED, LEICESTER

## DESCRIPTION: SECOND BOTTOM HEAD ADJUSTMENT

REF. NO.	PART DESCRIPTION	QUANTITY
1	20mm ID X 25mm OD X 25mm LONG BUSH	4
2	M12 X 30mm MALE ADJUSTING HANDLE	1
3	BEARING HOUSING FOR HEAD ADJUSTMENT SHAFTS	1
4	INPUT SHAFT	1
5	UNIVERSAL JOINT FOR BOTTOM HEAD RISE AND FALL	1
6	UNIVERSAL JOINT BEARING HOUSING	1
7	UNIVERSAL JOINT FOR BOTTOM HEAD AXIAL ADJUSTMENT	1
8	UNIVERSAL JOINT FOR BOTTOM HEAD RISE AND FALL LOCKING	1
9	BOTTOM HEAD MOUNTING	1

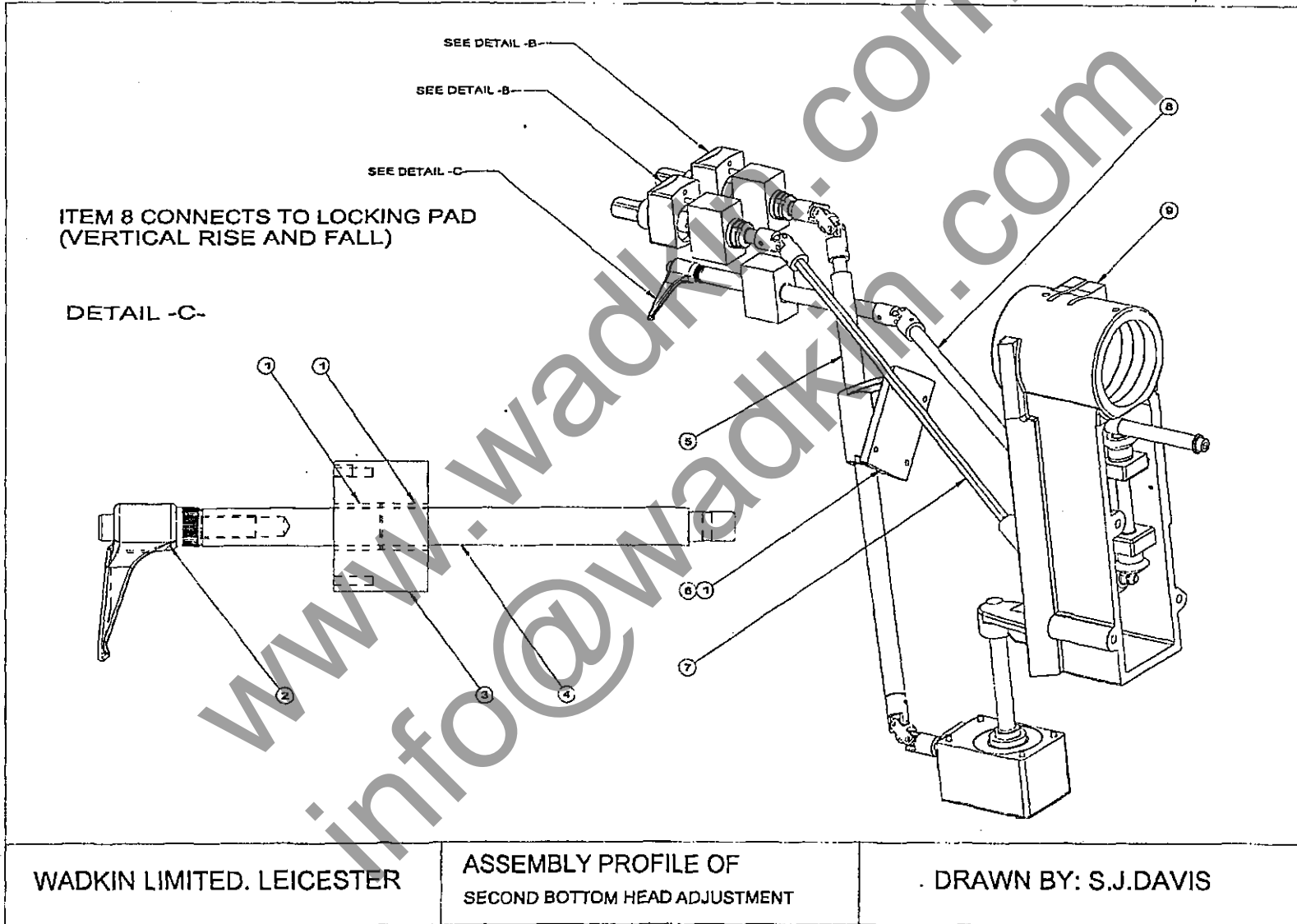

ILLUSTRATED PARTS LIST – MODEL K23  
WADKIN LIMITED, LEICESTER

DESCRIPTION: BOTTOM HEAD RISE & FALL BEVEL BOX

REF. NO.	PART DESCRIPTION	QUANTITY
1	SEALING RING	1
2	8mm X 7mm X 14 mm LONG KEY	1
3	LS-2542 INA THRUST WASHER	2
4	AXK-2542 INA THRUST BEARING	2
5	AS-2542 INA THRUST WASHER	2
6	M16 WASHER	1
7	M16 HEXAGON LOCK NUT	2
8	COVER FOR BEVEL BOX	1
9	M4 X 8mm HEXAGON SOCKET CAPSCREW	3
10	BOTTOM HEAD RISE AND FALL SCREW	1
11	BEVEL GEAR FOR TOP HEAD RISE AND FALL	1
12	25mm ID X 30mm OD X 25mm LONG BUSH	1
13	BEVEL BOX BOTTOM HEAD VERTICAL ADJUSTMENT	1
14	16mm DIAMETER EXTERNAL CIRCLIP	1
15	5mm X 5mm X 20mm LONG KEY	1
16	AS-2035 INA THRUST WASHER	4
17	END CAP RISE AND FALL BEVEL BOX	1
18	M6 SPRING WASHER SINGLE COIL	3
19	COLLAR	1
20	M6 X 75mm HEXAGON SOCKET CAPSCREW	4
21	BEVEL GEAR FOR TOP HEAD RISE AND FALL	1
22	CROSS SHAFT BOTTOM HEAD RISE AND FALL	1
23	AXK-2035 INA THRUST BEARING	2
24	20mm ID X 25mm OD X 25mm LONG BUSH	1
25	M6 X 25mm HEXAGON SOCKET CAPSCREW	3
26	M6 X 8mm GRUBSCREW	1



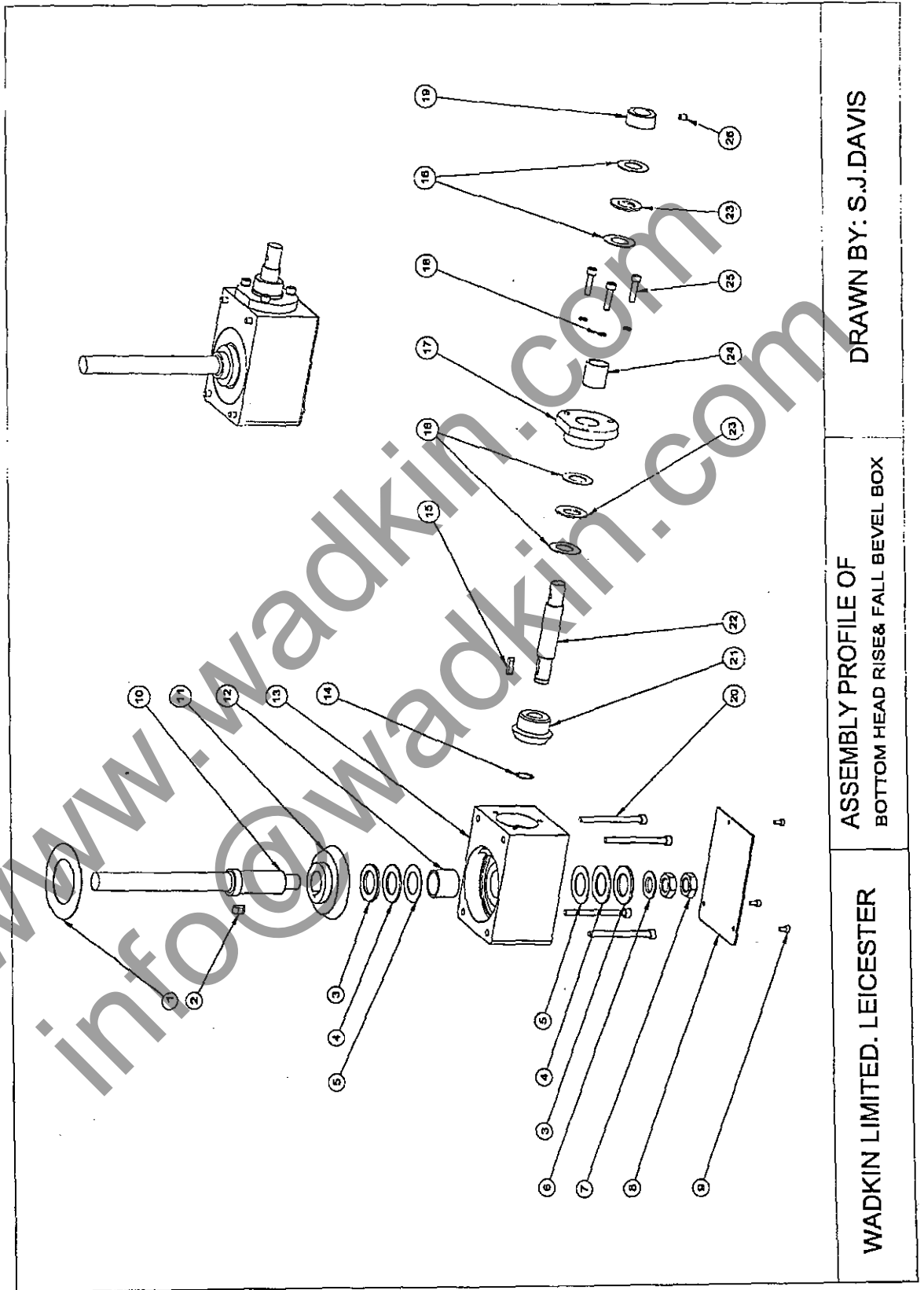

DRAWN BY: S.J.DAVIS

ASSEMBLY PROFILE OF  
BOTTOM HEAD RISE & FALL BEVEL BOX

WADKIN LIMITED. LEICESTER

ILLUSTRATED PARTS LIST – MODEL K23  
WADKIN LIMITED, LEICESTER

## DESCRIPTION: SECOND BOTTOM HEAD BARREL LOCKING

REF. NO.	PART DESCRIPTION	QUANTITY
1.	SECOND BOTTOM HEAD MOTOR	1
2	HORIZONTAL HEAD MOTOR BRACKET	1
3	SECOND BOTTOM HEAD DRIVE BELT	1
4	HORIZONTAL HEAD AXIAL ADJUSTMENT PIVOT BAR	1
5	BACKPLATE FOR SECOND BOTTOM HEAD BELT COVER	1
6	HORIZONTAL HEAD AXIAL ADJUSTMENT SPINDLE LOCKING BLOCK	1
7	HORIZONTAL HEAD AXIAL ADJUSTMENT THREADED LOCKING SHAFT	1
8	SG-M8 FESTO CLEVIS	1
9	SECOND BOTTOM HEAD SPINDLE	1
10	BOTTOM HEAD AXIAL ADJUSTMENT PIVOT BLOCK	1
11	PFA360/SP3 PNEUMATIC TOGGLE CLAMP	1
12	SECOND BOTTOM HEAD HOUSING	1

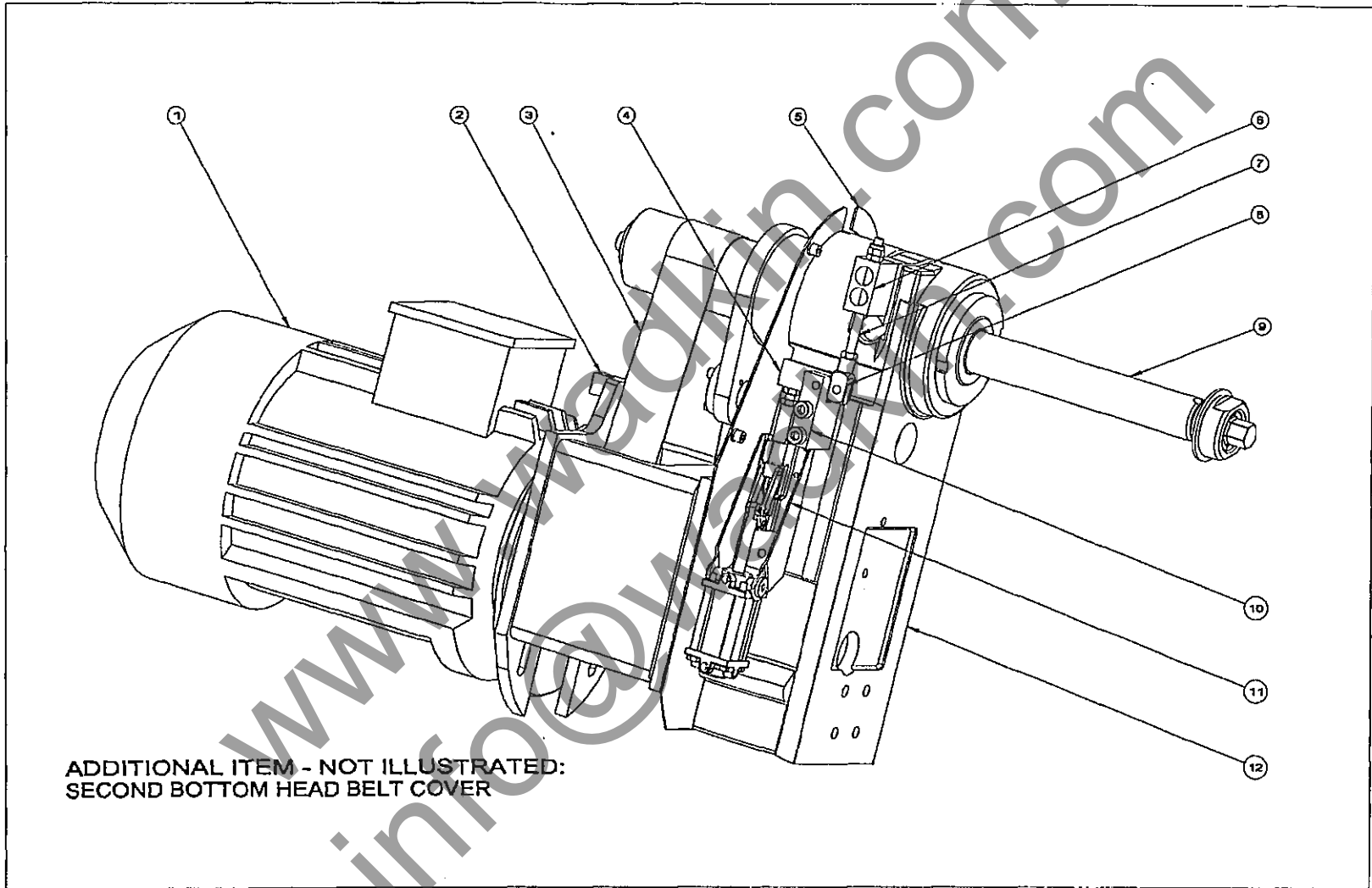

WADKIN LIMITED. LEICESTER

ASSEMBLY PROFILE OF  
SECOND BOTTOM HEAD BARREL LOCKING

DRAWN BY: S.J.DAVIS

ILLUSTRATED PARTS LIST – MODEL K23  
WADKIN LIMITED, LEICESTER

DESCRIPTION: BEAM AND GEARBOX ARRANGEMENTS

REF. NO.	PART DESCRIPTION	QUANTITY
1	GEARBOX –TYPE 1	5
2	PULLEY/COUPLING	2
3	COUPLING – TYPE 1	6
4	GEARBOX EXTENSION SHAFT	1
5	COUPLING – TYPE 2	4
6	GEARBOX – TYPE 2	3
7	TIMING BELT PULLEY – TYPE 1	2
8	TAPER LOCK BUSH – TYPE 1	2
9	GEARBOX – TYPE 3	3
10	TIMING BELT PULLEY – TYPE 2	2
11	TAPER LOCK BUSH – TYPE 2	2
12	TIMING BELT – INFEEED BOTTOM AND INTERMEDIATE BOTTOM	2
13	CONNECTING SHAFT	2
14	TIMING BELT – OUTFEED BOTTOM	1
	MINEX GEAR RING NO. 28 (NOT SHOWN) PLACED BETWEEN COUPLINGS	
	EACH GEARBOX HOLDS OUTPUT SHAFT (I70 BOX)	

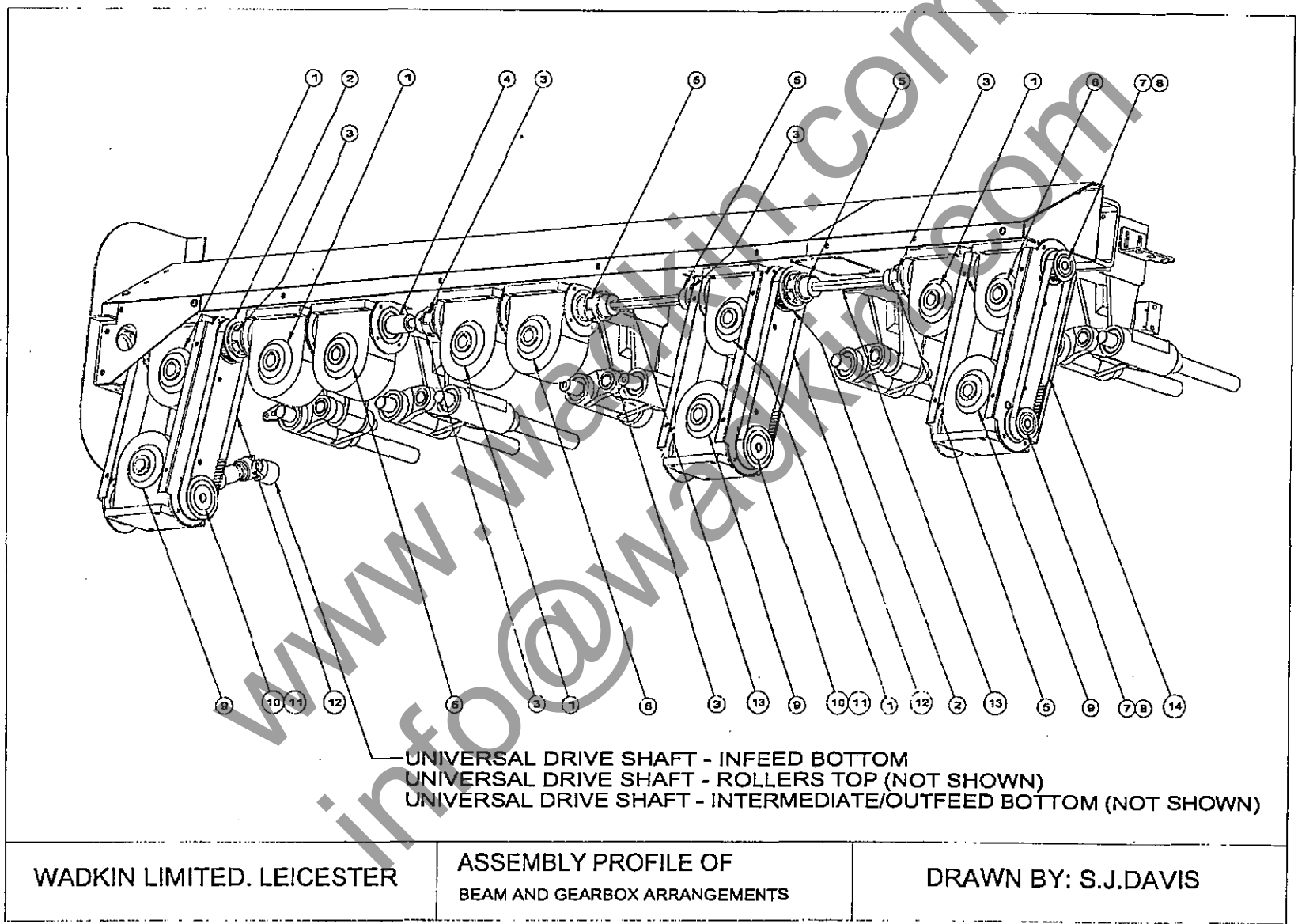

UNIVERSAL DRIVE SHAFT - INFEEED BOTTOM  
UNIVERSAL DRIVE SHAFT - ROLLERS TOP (NOT SHOWN)  
UNIVERSAL DRIVE SHAFT - INTERMEDIATE/OUTFEED BOTTOM (NOT SHOWN)

WADKIN LIMITED. LEICESTER	ASSEMBLY PROFILE OF BEAM AND GEARBOX ARRANGEMENTS	DRAWN BY: S.J.DAVIS
---------------------------	------------------------------------------------------	---------------------

ILLUSTRATED PARTS LIST – MODEL K23  
WADKIN LIMITED, LEICESTER

DESCRIPTION: SIMPLABELT Z CONFIGURATION VARIABLE SPEED DRIVE

REF. NO.	PART DESCRIPTION
1	NAME PLATE – DRIVE UNIT COMPLETE
2	NAME PLATE – MOTOR
3	NAME PLATE – GEARBOX
1.01	MECHANICAL ADJUSTMENT VARIABLE SPEED PULLEY
1.02	SPRING LOADED VARIABLE SPEED PULLEY
1.03	WIDE SECTION V-BELT
1.04	HOUSING
1.05	HOUSING
1.09	COVER
1.10	WASHER
1.11	SOCKET HEAD CAPSCREW DIN 912
1.12	HEXAGON HEAD SCREW DIN 931
1.15	SOCKET HEAD CAPSCREW DIN 912
1.16	HEXAGON NUT DIN 934
1.17	PIN (ONLY FOR SIZES 20, 25, 31)
1.18	SOCKET HEAD CAPSCREW DIN 912
1.20	HEXAGON HEAD SCREW DIN 933
1.23	HEXAGON HEAD SCREW DIN 933
1.28	NUT INSERT
1.29	SCREW DIN 7500
1.30	PERFORATED DISC
1.31	AXIAL TIGHTENING SCREW
1.32	COVER FOR SPEED INDICATION
1.33	COVER FOR IMPULSE RECORDER
3.01	FRONT ADJUSTMENT
3.02	ANGULAR ADJUSTMENT
3.03	SERVO ADJUSTMENT
5.00	MOTOR
6.00	GEARBOX
7.08	IMPULSE RECORDER
8.01	HOUSING COVER
8.02	TACHO GENERATOR
8.05	HEXAGON HEAD SCREW DIN 933
8.06	WASHER DIN 7349
8.07	CAP NUT DIN 986
8.08	STUDING DIN 835
8.09	HEXAGON NUT
8.10	PIN DIN 1481
8.11	SCREW GLAND
10.00	ANALOGUE INDICATOR DEVICE
11.00	DIGITAL INDICATOR DEVICE
	INFORMATION SUPPLIED BY LENZE POWER TRANSMISSION

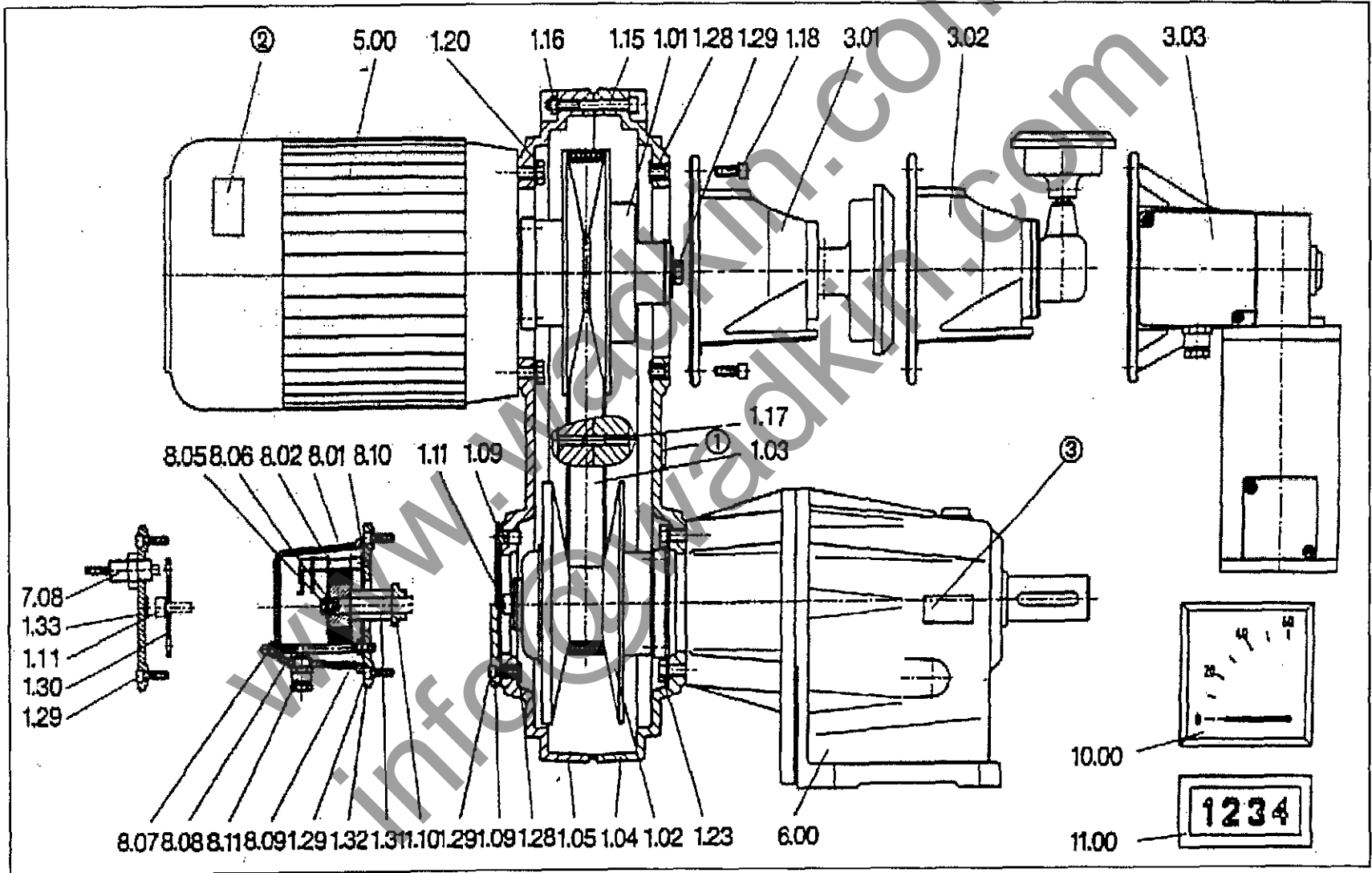

ILLUSTRATED PARTS LIST – MODEL K23  
WADKIN LIMITED, LEICESTER

DESCRIPTION: BEAM RISE & FALL BEVEL BOX

REF. NO.	PART DESCRIPTION	QUANTITY
1	RISE AND FALL NUT	1
2	BEAM RISE AND FALL SCREW	1
3	6mm X 6mm X 32mm LONG KEY	1
4	M6 X 25mm HEXAGON SOCKET CAPSCREW	4
5	25mm ID X 30mm OD X 20mm LONG BUSH	1
6	M6 WASHER	4
7	TOP COVER FOR WORMGEAR HOUSING	1
8	WORM FOR BEAM RISE AND FALL	1
9	AS-2035 INA THRUST WASHER	3
10	AXK-2035 INA THRUST BEARING	2
11	47mm DIAMETER INTERNAL CIRCLIP	2
12	WORMGEAR HOUSING	1
13	20mm ID X 25mm OD X 20mm LONG BUSH	1
14	LS-2035 INA THRUST WASHER	1
15	M20 HEXAGON LOCKNUT	2
16	6204-2RS RHP & SKF BEARING	2
17	WORM WHEEL FOR BEAM RISE AND FALL	1
18	6mm X 6mm X 20mm LONG KEY	2
19	FEEDWORKS BEAM SUPPORT SLIDE	1
20	BRACKET FOR RISE AND FALL GEARBOX	1



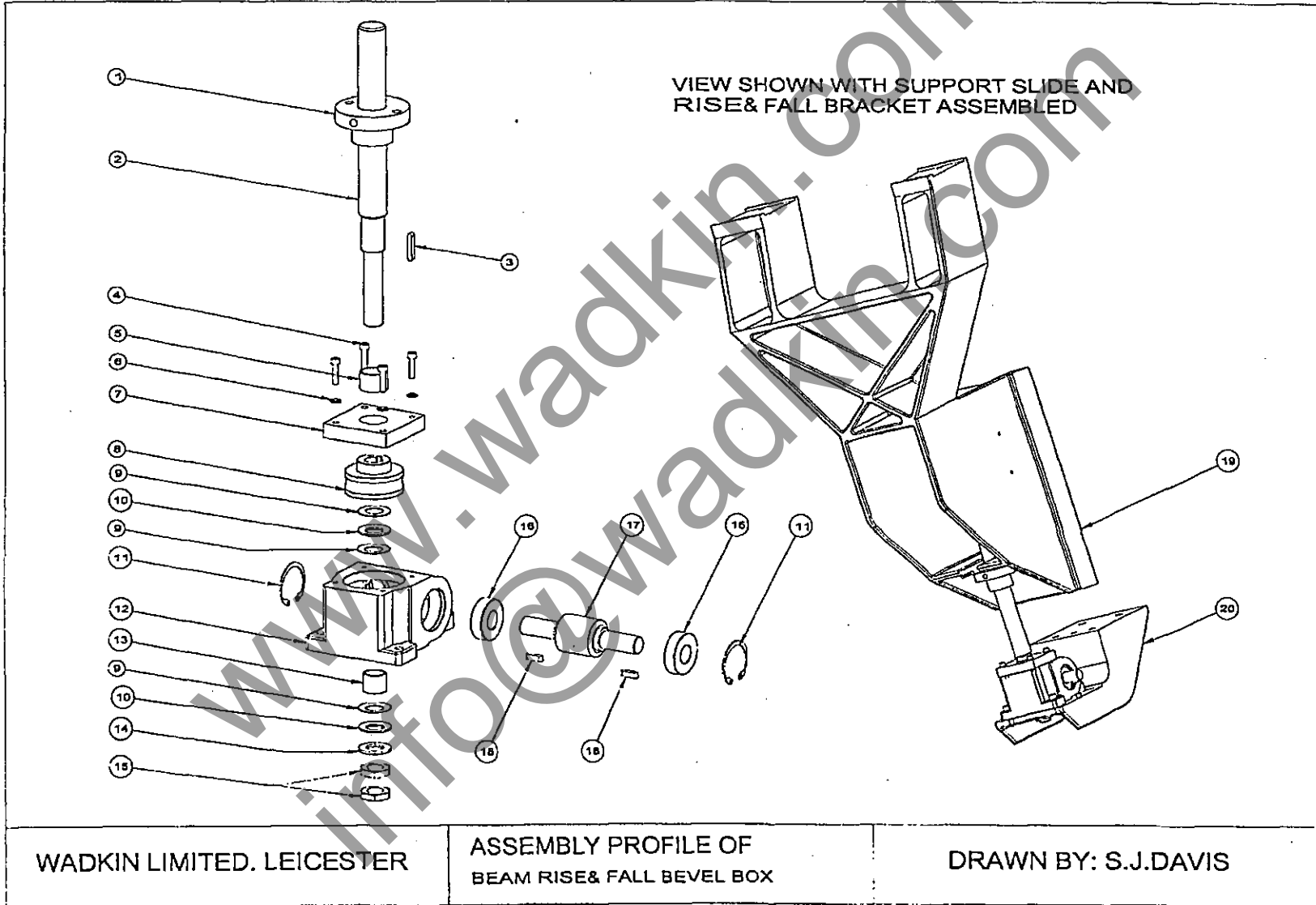

ILLUSTRATED PARTS LIST – MODEL K23  
WADKIN LIMITED, LEICESTER

DESCRIPTION: SHAFT MOUNTED FEEDROLL

REF. NO.	PART DESCRIPTION	QUANTITY
1	WDS.614.204 M12 THUMB NUT	1
2	VCT50FP-M12 LOBE KNOB	1
3	BRACKET FOR FEEDROLL SWINGS	1
4	FEEDROLL HEIGHT ADJUSTING STUD	1
5	SG-M12 FESTO CLEVIS	1
6	EYEBOLT FOR FEEDROLL ADJUSTMENT	2
7	SWING PIVOT SHAFT	1
8	25mm ID X 30mm OD X 25mm LONG BUSH	2
9	50mm OD X 25.4mm ID DISC SPRING	2
10	SPACER FOR FEEDROLL SWING	1
11	ANCHOR BRACKET RIGHT HAND FOR FEEDROLL ADJUSTMENT	1
12	PNEUMATIC CYLINDER	1
13	FEEDROLL SWING	1
14	KEY FOR FEEDROLL SHAFT	1
15	FEEDROLL SHAFT	1
16	8mm X 7mm X 30mm LONG KEY	1
17	6006-2RS RHP & SKF BEARING	2
18	30mm DIAMETER EXTERNAL CIRCLIP	3
19	SV30X8SS RENCOL TOLERANCE RING	1
20	55mm DIAMETER INTERNAL CIRCLIP	1

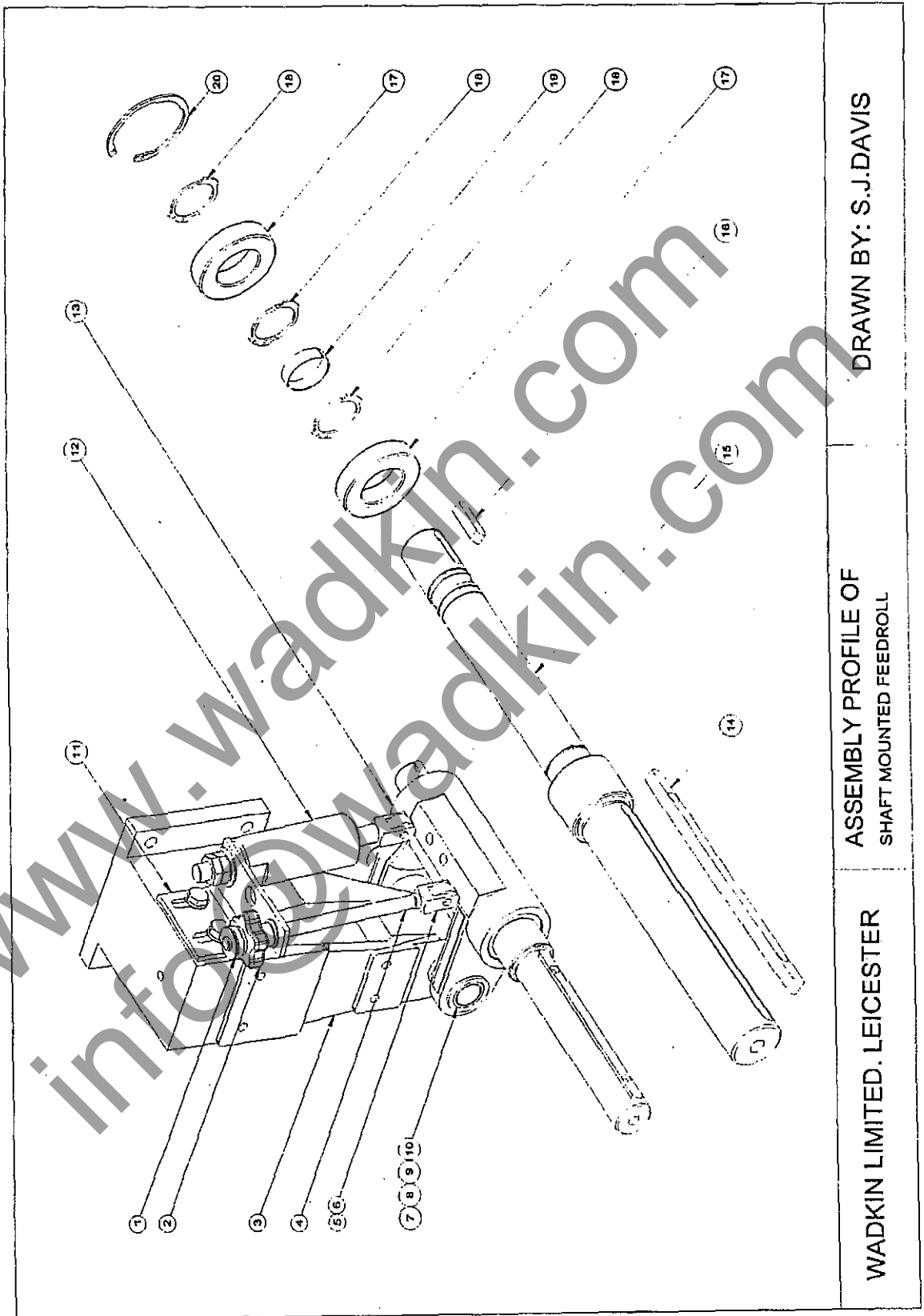

DRAWN BY: S.J.DAVIS

ASSEMBLY PROFILE OF  
SHAFT MOUNTED FEEDROLL

WADKIN LIMITED. LEICESTER

ILLUSTRATED PARTS LIST – MODEL K23  
WADKIN LIMITED, LEICESTER

DESCRIPTION: FLANGED MOUNTED FEEDROLL

REF. NO.	PART DESCRIPTION	QUANTITY
1	ANCHOR BRACKET LEFT HAND FOR FEEDROLL ADJUSTMENT	1
2	FEEDROLL SWING	2
3	SWING PIVOT SHAFT	1
4	25mm ID X 30mm OD X 25mm LONG BUSH	4
5	50mm OD X 25.4mm ID DISC SPRING	2
6	ANCHOR BRACKET RIGHT HAND FOR FEEDROLL ADJUSTMENT	1
7	BRACKET FOR FEEDROLL SWINGS	1
8	PNEUMATIC CYLINDER	2
9	EYEBOLT FOR FEEDROLL ADJUSTMENT	2
10	FEEDROLL MOUNTING FLANGE	1
11	6006-2RS RHP & SKF BEARING	4
12	FEEDROLL SHAFT	2
13	8mm X 7mm X 36mm LONG KEY	2
14	30mm DIAMETER EXTERNAL CIRCLIP	2
15	55mm DIAMETER INTERNAL CIRCLIP	2

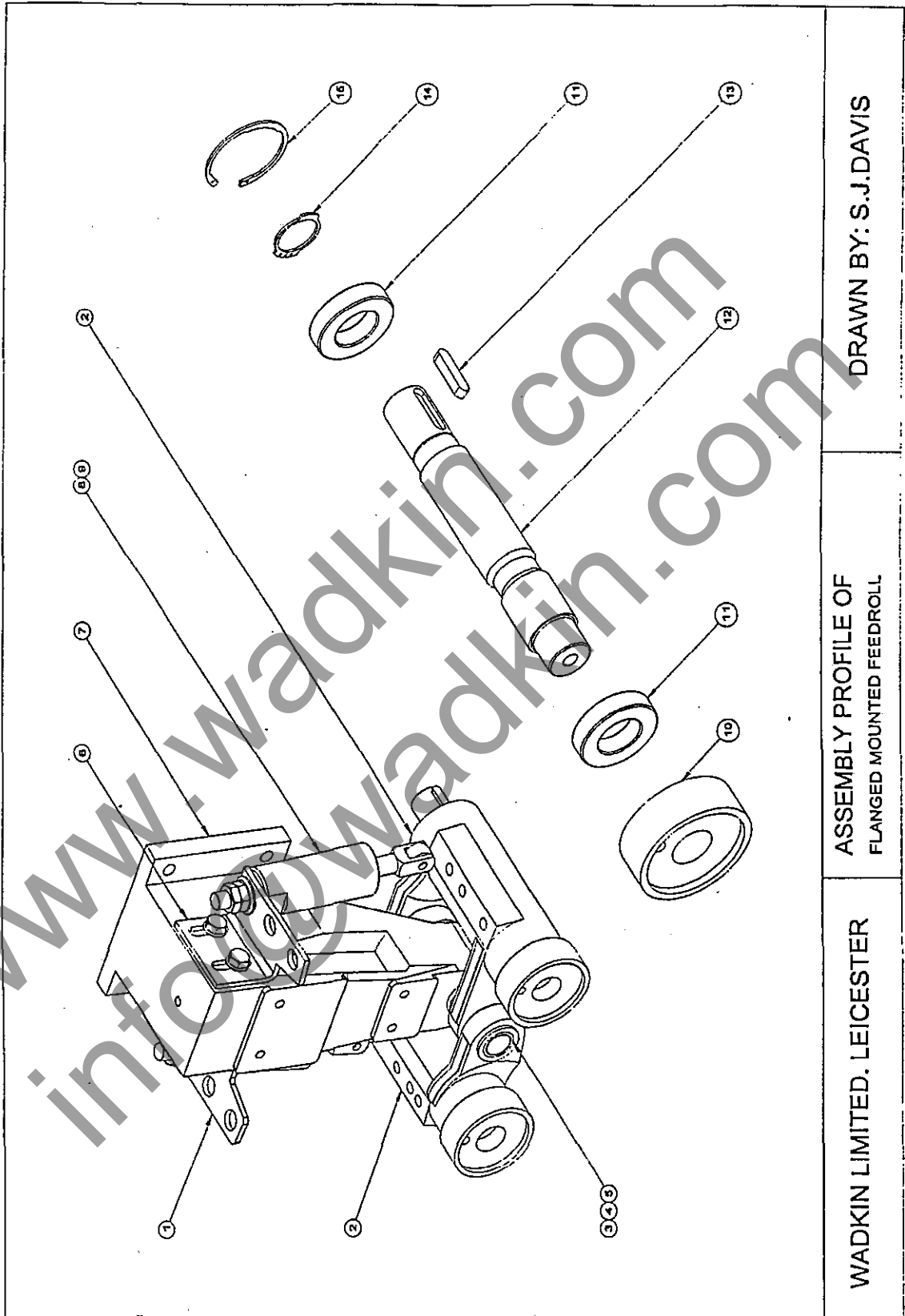

DRAWN BY: S.J.DAVIS

ASSEMBLY PROFILE OF  
FLANGED MOUNTED FEEDROLL

WADKIN LIMITED. LEICESTER